

# A Gregorian Chant Coloring Book For Children & Adults

Gregorian Chant is simple  
and easy to learn.

A small box of  
crayons, markers or colored pencils  
and you are on your way to  
learn and remember  
how to read Gregorian Chant.

Colors you need:  
Black Green Red Blue Yellow  
Any others for coloring words.

Noel Jones, AAGO • Author

Alan Dash • Illustrator

Ellen Doll Jones, CAGO • Lauren Gadd  
Editors

[www.sacredmusiclibrary.com](http://www.sacredmusiclibrary.com)

Frog Music Press  
636 Old 19  
Augusta, KY 41002

[info@sacredmusiclibrary.com](mailto:info@sacredmusiclibrary.com)

Copying and Sharing of this book are not only permitted but encouraged.

This book is protected under the provisions of Creative Commons 3.0  
against use for commercial purposes.

# The Creation of Written Music.

Sing this sentence on one pitch:

In the name of the Father, and of the Son, and of the Holy Spirit, Amen.

Now sing it, but sing just "Fa" of Father one note higher. We will draw a line above "Fa" to remind you to sing it a note higher:

In the name of the Father, and of the Son, and of the Holy Spirit, Amen.

Now sing it, and now sing the "A" of Amen one note lower. We will underline the "A".

In the name of the Father, and of the Son, and of the Holy Spirit, Amen.

So we can sing 3 different notes, marking them using lines. And that's how sung music works:



In the name of the Father, and of the Son, and of the Holy Spirit, Amen.

This is how music notes are written.

This page can be presented on a blackboard as an introduction by the teacher, having the students singing the line, first in monotone and then with the raised and lowered notes, before the coloring books are opened for the first time.

Pitches...Any pitches may be sung, but Do Re Do Do work nicely.  
Ti

On the piano that can be C D C B C or F G F E F.

# A Quick Reference Page

## The Chant Musical Alphabet

**Do  
Ti  
La  
So  
Fa  
Mi  
Re  
Do**

We are all familiar with this alphabet going up as a result of "The Sound Of Music" and the song: "Do, a deer..."

But people have trouble singing it from the top down. But we can fix that.

Sing:

**Joy to the world, the Lord is come!**

Now sing it with these words:

**Do Ti La So, Fa Mi Re Do**

Now you know how to sing the chant alphabet up and down.

# Table of Contents

Staff	6-7
Ledger Lines	8
Neumes	9
Punctum	10-12
Do Clef	13
Clefs	15-7
Staff Lines	18-20
Scale	21-8
Connections	30
Clivis	31-32
Virga	31
Inclinatorum	33-34, 36
Podatus	35, 36
Torculus	37
Porrectus	38-39
Fa Clef	41-43
Flat	44
Natural	44
Liquescent	45
Held Notes	46-47
Punctum Mora	46
Quilisma	47
Horizontal Episema	48
Vertical Episema	49
Salicus	49
Stropha	50
Bar Lines	51
Custos	52
Illuminated Text	53

## Chant Hymns

Godhead Here I Hiding	58
Hail, O Star That Pointest	60
Creator of the Stars Of Night	62
At The Cross	64
Bright Torches	66
Jesus Thou Joy	68
O Come, Redeemer	70



Color each of these four lines black.

Drawing four lines to write music on is the great invention that created *Gregorian Chant* and eventually, the way music is written today.

These lines are like train tracks, equally spaced apart and never touching each other.



Color these 4 lines black and answer this question:

How many spaces are there between the lines?

Color the correct number with a black crayon,  
Color the others red:

1 2 3 4

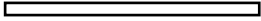



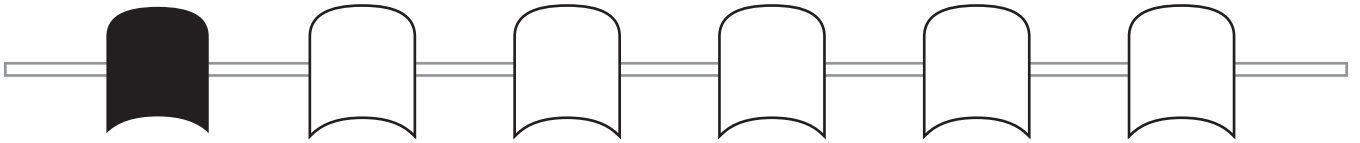

## Neumes

The marks the pitches you sing are called neumes. The first neume to learn is named Punctum. It looks like an eraser on a pencil.

Color the 4 staff lines black. Color all the punctum neumes black.

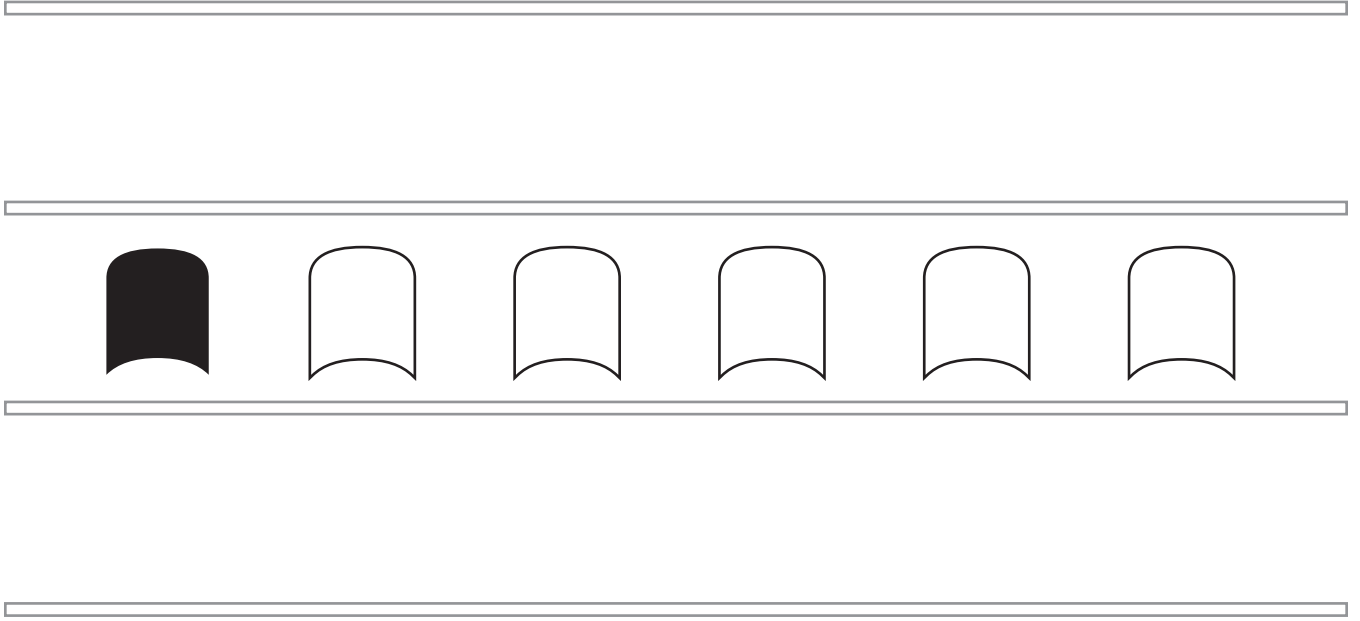

## The Punctum - Dot

It may be on a space or on a line.

Color the 4 staff lines black. Color all the punctum neumes black.

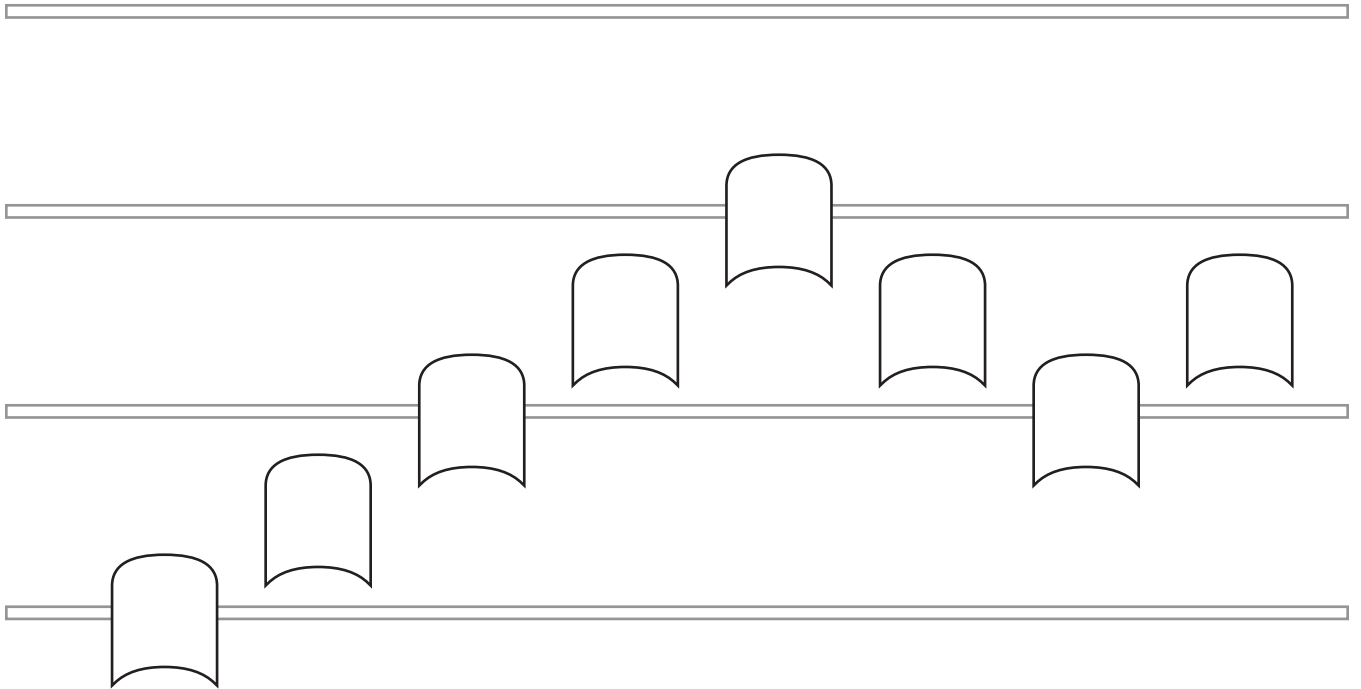

## The Punctum - Dot

On spaces and lines. Color the lines black. Color the punctum black on this page. Today people use calligraphic pens or markers to draw these curved neumes. Originally they were drawn with a wide quill pen with a thin edge so the scribe could draw thin or wide lines without lifting the quill point from the page.

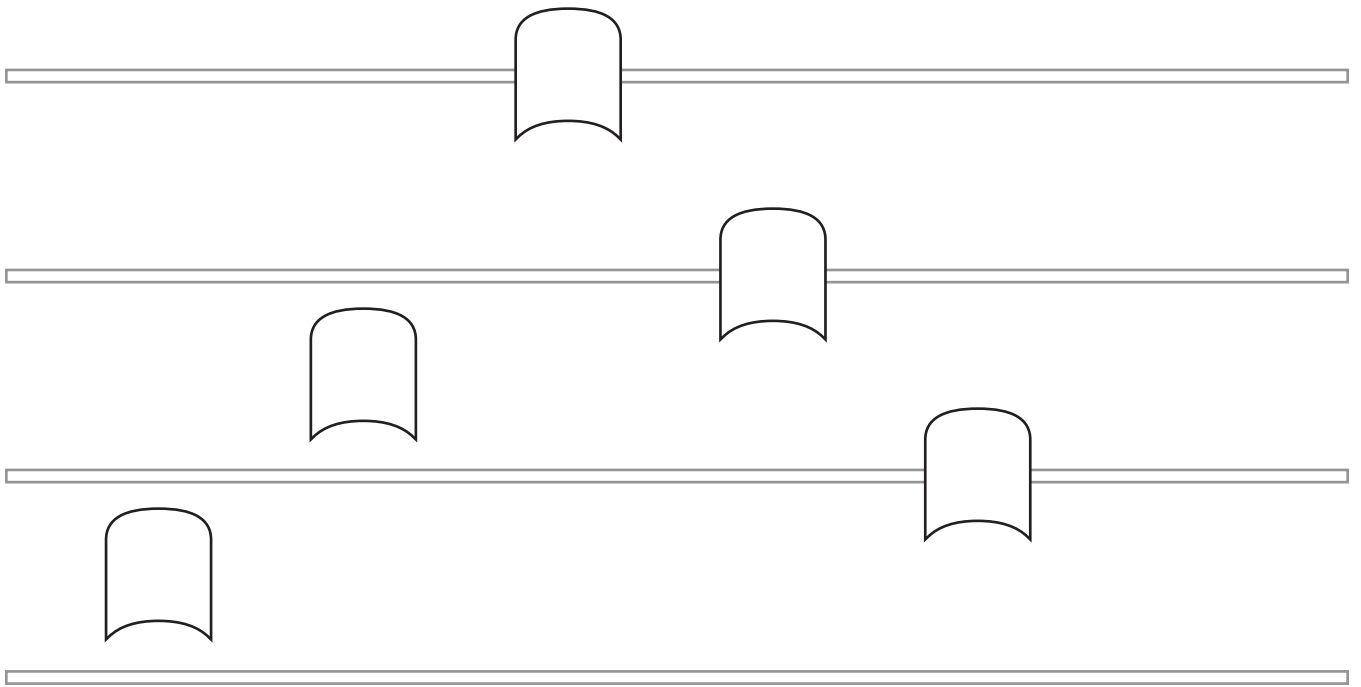

## The Punctum

These punctum hop over lines and spaces. In music some notes go step by step and others skip over lines and spaces. The distance between the notes is measured as an interval.

Color these punctum all black and the lines black, too.

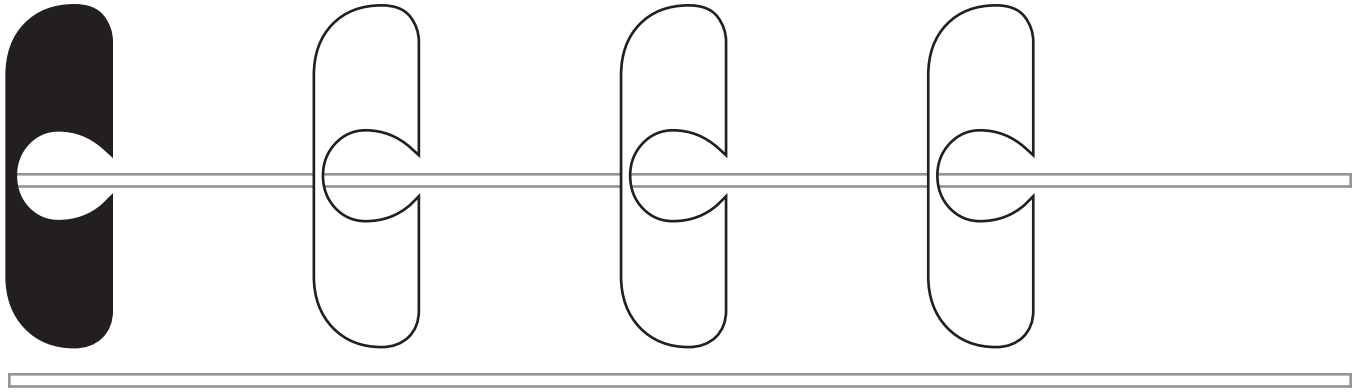



### The Do Clef

It can be moved from line to line to center a melody on the staff.

Color the Do Clef green and the line it is on green, the other lines black.





### Clefs - Coloring the Fa line red.

Colors: Do clef line green and the line green too.  
Second line from top Black  
Third line from top Red,  
Fourth line from top Black



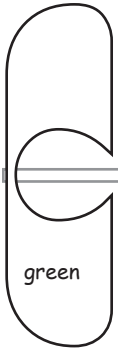

green

green

black

black

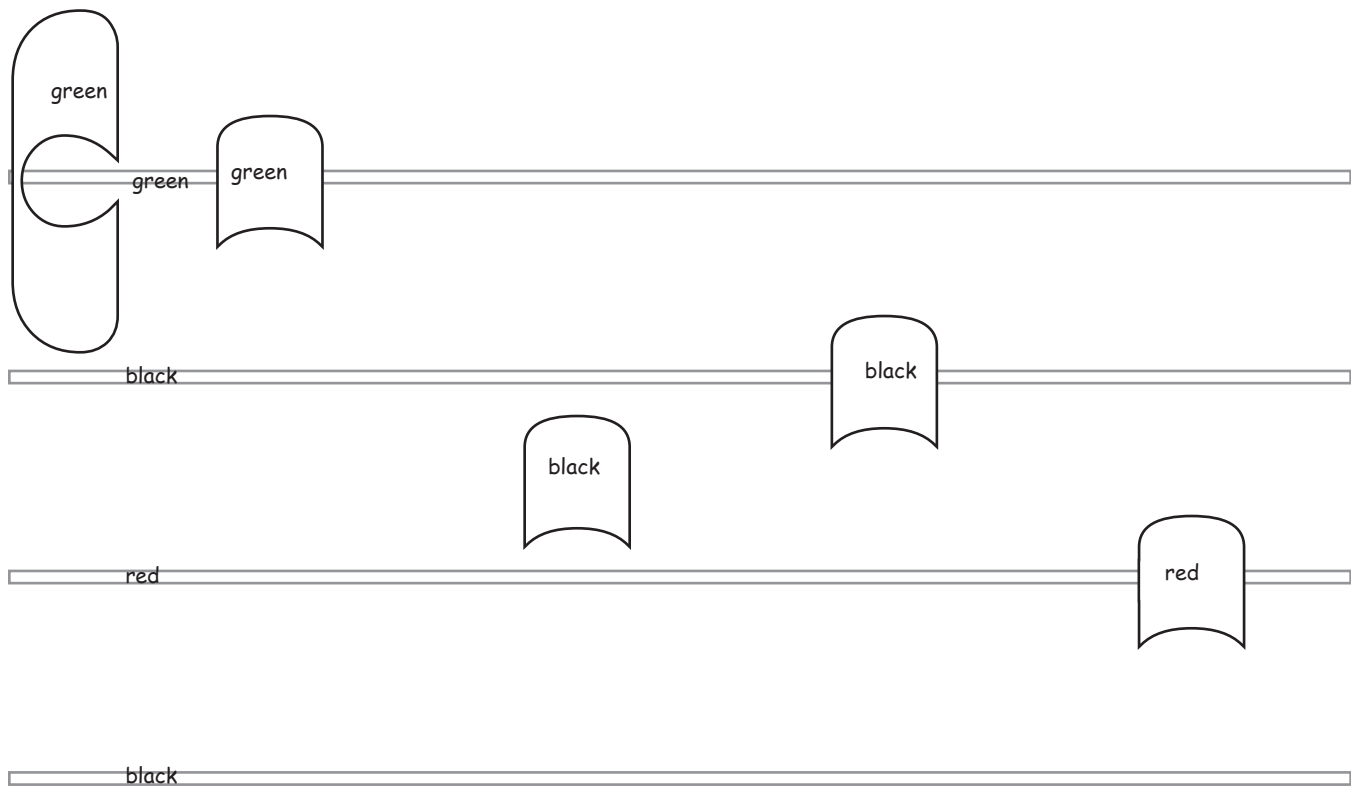

## Staff Lines

Coloring neumes green and red when they are on spaces and lines for Do & Fa helps us learn and remember where pitches are on the staff

The image shows five musical staves with notes and lyrics. The notes are labeled with colors: green, black, red, and do/green. The lyrics are re, do, ti, la, so, fa, mi, re, do.

Staff	Note Color	Lyrics
1	green	re
2	black	do
3	black	ti
4	black	la
5	black	so
6	red	fa
7	black	mi
8	black	re
9	do/green	do

### Staff Lines

Do, the green line and notes and Fa, the red line and notes, are special. Always color the lines first and then the notes, making sure that you color all notes black except for Do and Fa.

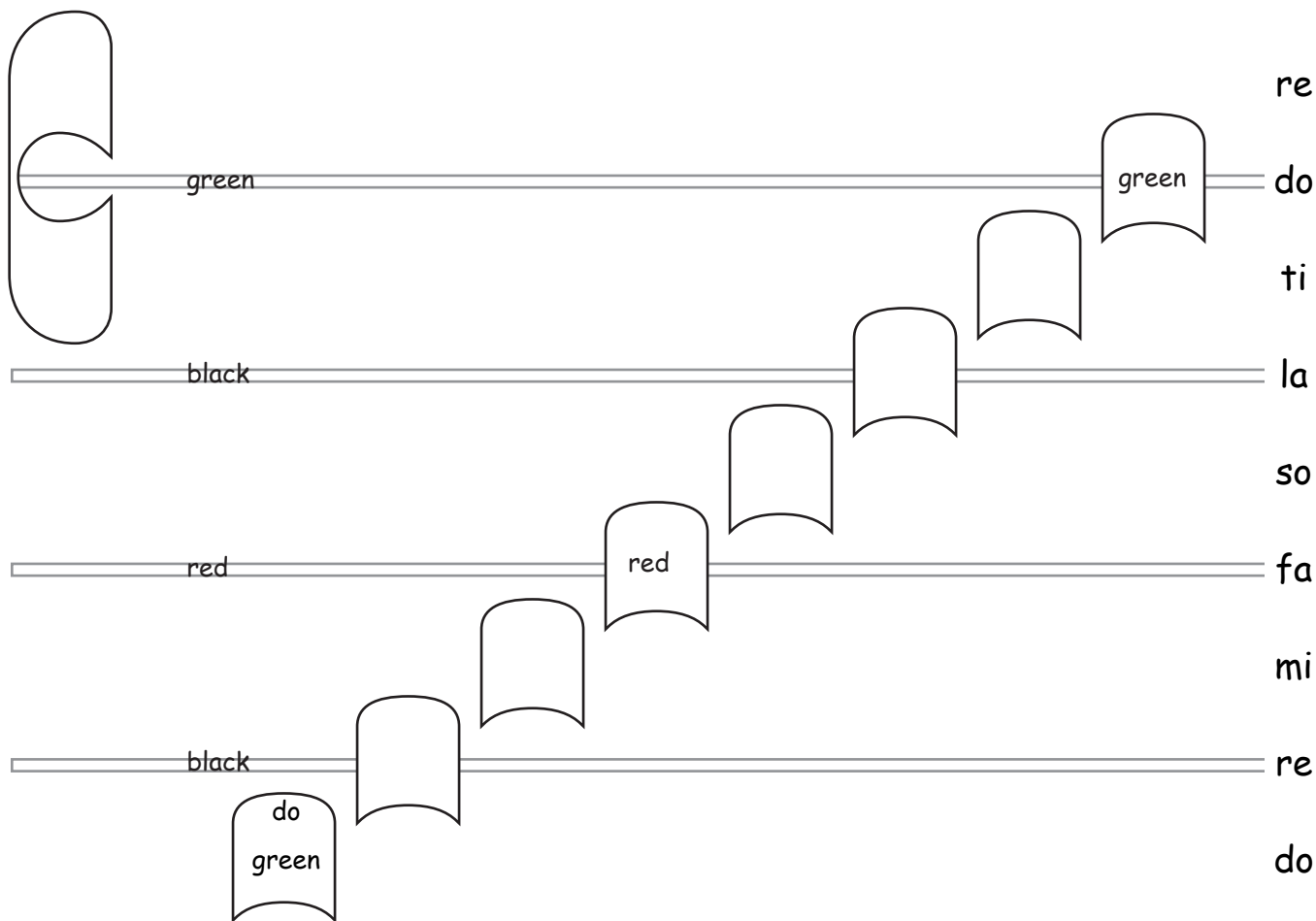

### Staff Lines

Do and Fa are like bases in Baseball. You need to know where they are all the time when you sing chant. And they can move!

## Understanding Do Re Mi...

The musical scale repeats it self going up and then back down.

The pitch (how high or low it sounds) changes, getting faster as it goes up. When it gets faster we say it sounds higher.

It doubles. When you sing "a" below middle "c" on the piano, your vocal chords move 220 times a second while the next "a" up the scale is 440 times a second so they move twice as fast.

Color every Do on this page green, every Fa red and all other pitch names black.

There are other scales that people sing around the world that use different pitches. One African scale has only 4 pitches in the space between Do to Do, 4 notes where we have 6.

"Do" can move.

"Fixed Do" is when Do is always C.

Moveable Do can be higher or lower than middle C on the piano. This is "moveable do".

Chant singers can use Fixed Do or Moveable Do when it fits the vocal range of the singers.

Do

Ti

La

So

Fa

Mi

Re

Do

Ti

La

So

Fa

Mi

Re

Do

re

do

ti

la

so

fa

mi

re

do

re

do

ti

la

so

fa

mi

re

do

green

black

red

black

Color the Fa line and the Fa punctum red.

Color the notes on lines to match the lines and always color the notes on spaces black unless they are Do [green] or Fa [red]. On the next page you will find your first Do on a space.

re  
do  
ti  
la  
so  
fa  
mi  
re  
do

green  
black  
red  
black  
black  
green

Do and every other note occurs every 8 lines and spaces going up and down. Here it falls on the space below the staff.



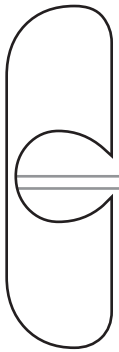

green

re

do

ti

la

so

red

red

fa

black

mi

black

re

green

do

Color the notes and lines.

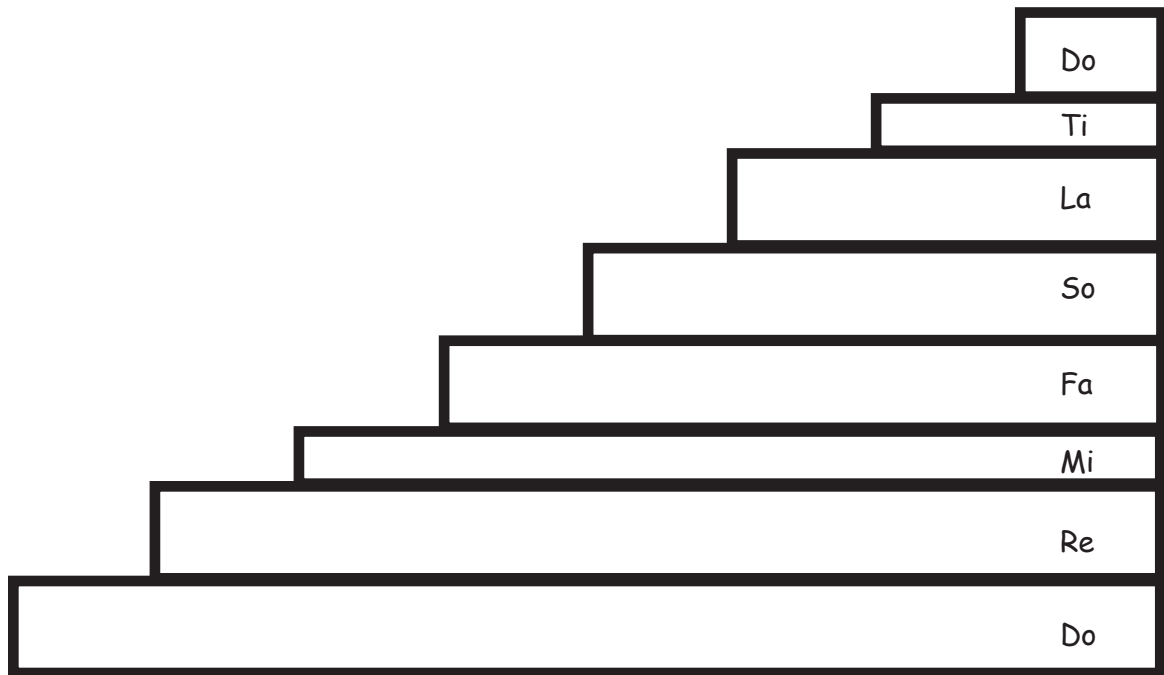

### Understanding the scale

Musical notes are arranged like the steps above. But note that two steps are half the height of others. For that reason, Fa and Do sound different when we get to them.

These short steps lead us to the full step above and are called leading tones.

Color Do green and Fa red on this page and the Ti and Mi leading tones blue.

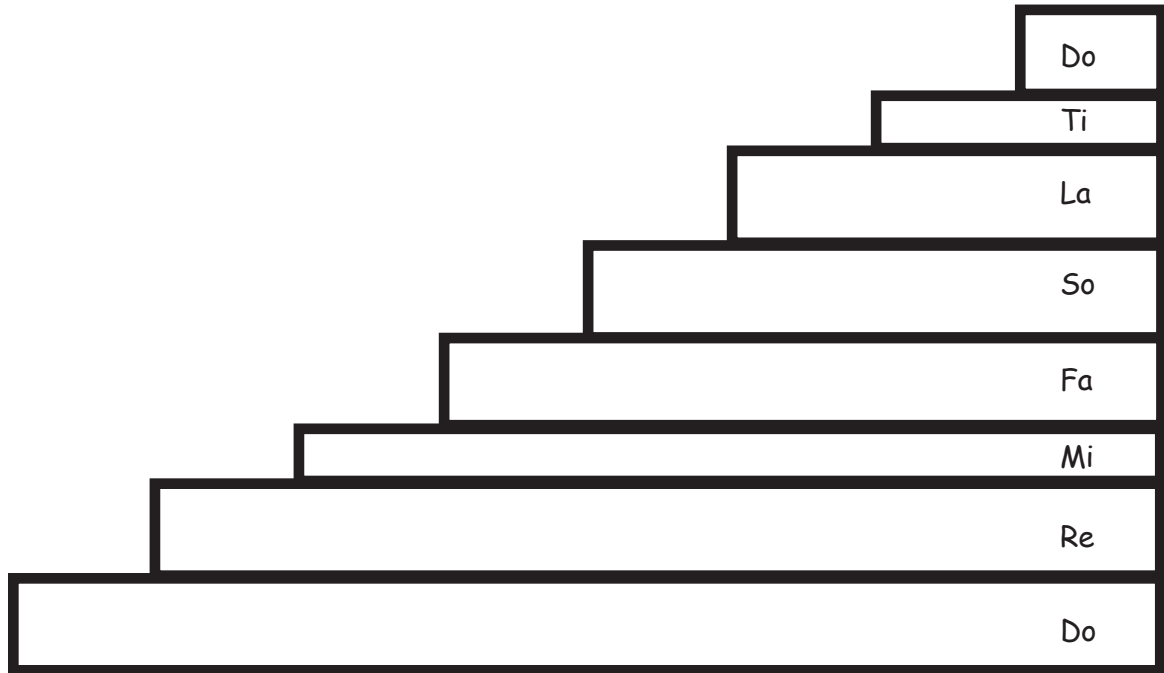

Color Do - Green, Fa - Red, Mi & Ti Blue and the remaining pitches Re, So and La Yellow

Today's modern music usually starts and always ends in Do in one way or another and that's why chant sounds different since it can start and end on any note.

Your ear will learn where the small steps, leading tones, are on the scale. Remember, they are always just under Do and Fa. These two leading tones make our music sound the way it does and make Do and Fa more important in the scale. Without the leading tones every note would sound alike and the sound of our music would be less interesting to the ear.



Color the neumes the correct colors.

There will be one red neume. How many green ones will there be?

Remember, Do is green. Color all the neumes that are not green or red black.

re  
do  
ti  
la  
so  
fa  
mi  
re  
do

*A- men, a- men.*

### More neumes

With the neumes you already now, you can sing any chant already written. So why learn more neumes?

Just like a Lego™ set, chant uses building blocks of chant neumes. Color the sung text, the words underneath the staff, any colors you like.

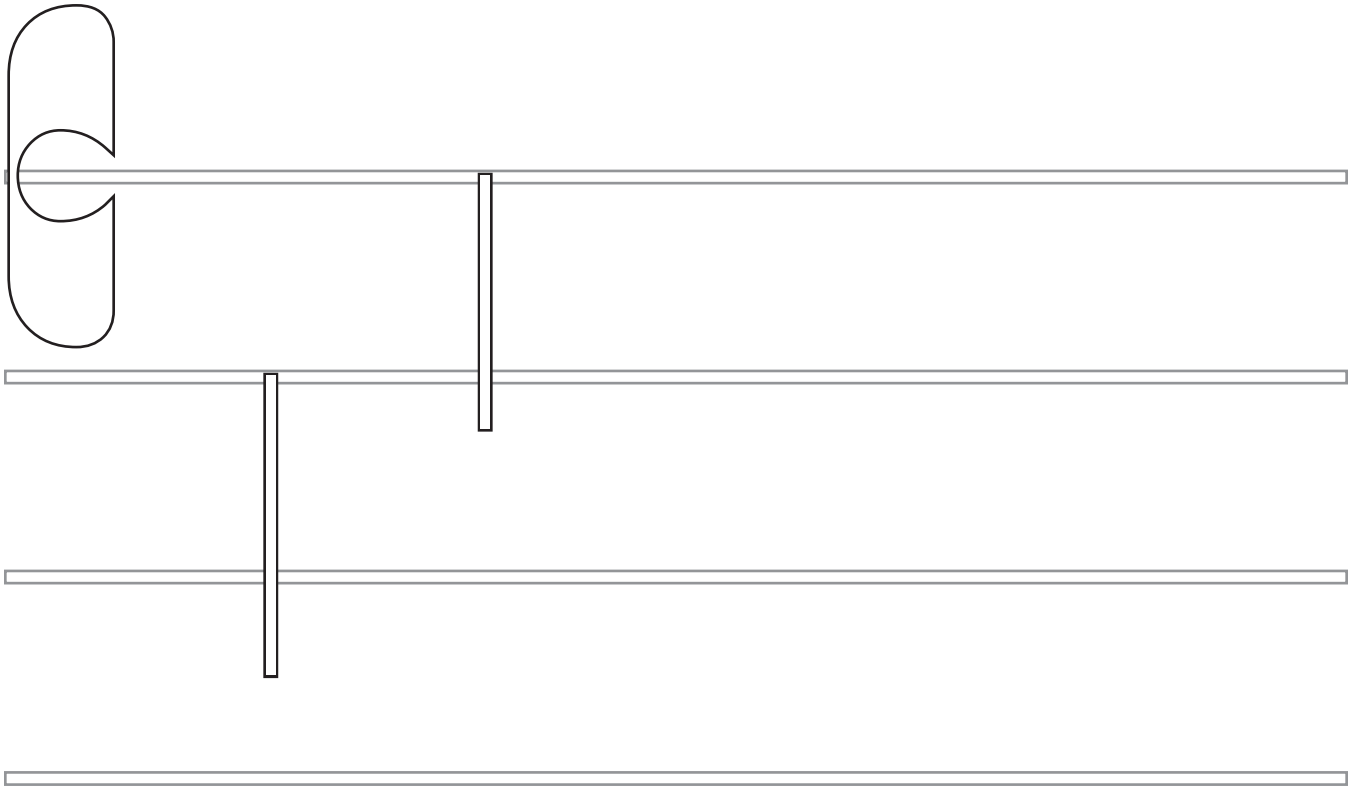

## Connections

Lines are very important. Sometimes we sing more than one pitch to a word or syllable. Chant uses special signs to tell you to stretch the vowel are singing over more than one note. One of the signs is a line.

A line can be added to a punctum. Lines may also connect neumes that are sung together.

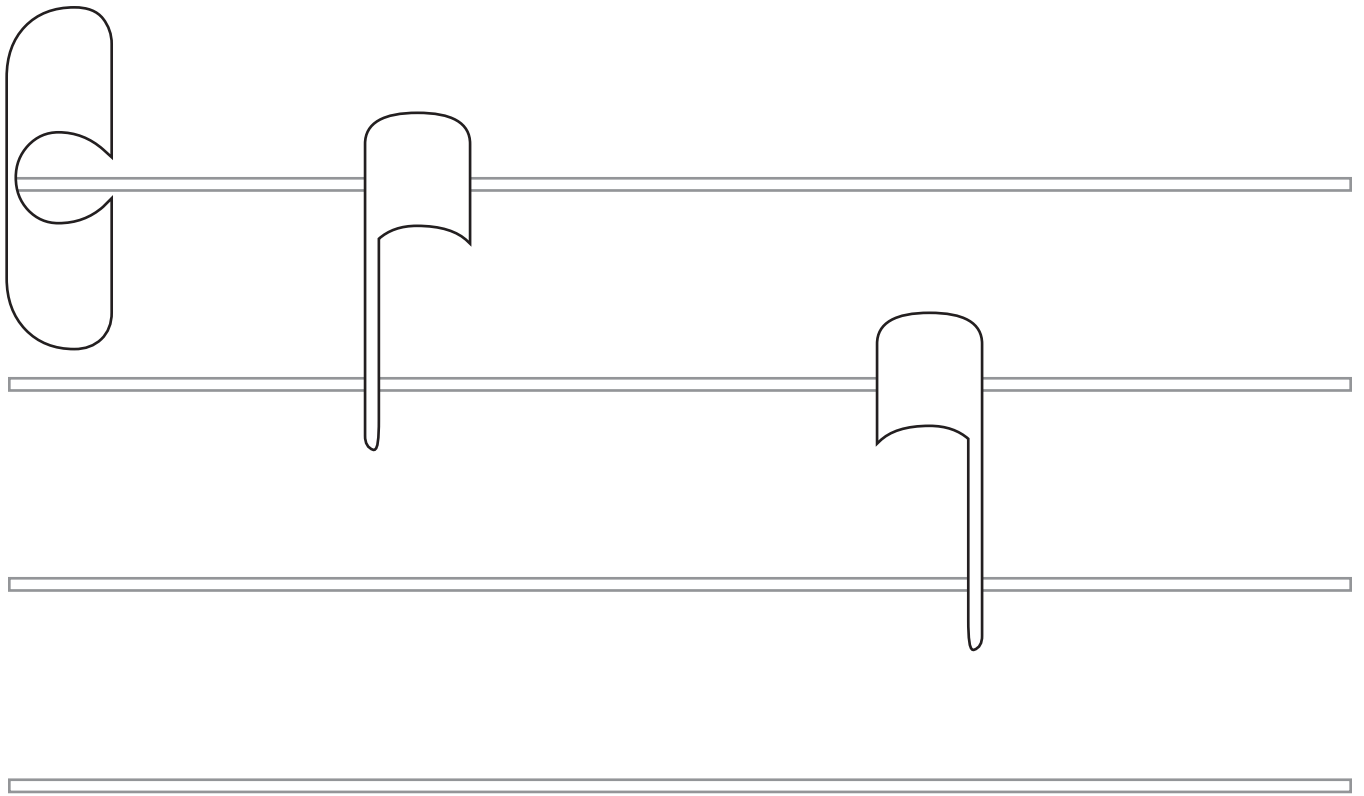

The punctum with a trunk or a tail.

When a line falls like an elephant's trunk from the left side of a punctum it is called a *Clivis*. When it is on the right of a neume like the tail of a donkey, it's a *Virga*.

The trunk and tail tell you that this is not a punctum to be sung by itself, Instead it is the first of a group of neumes to be sung together.

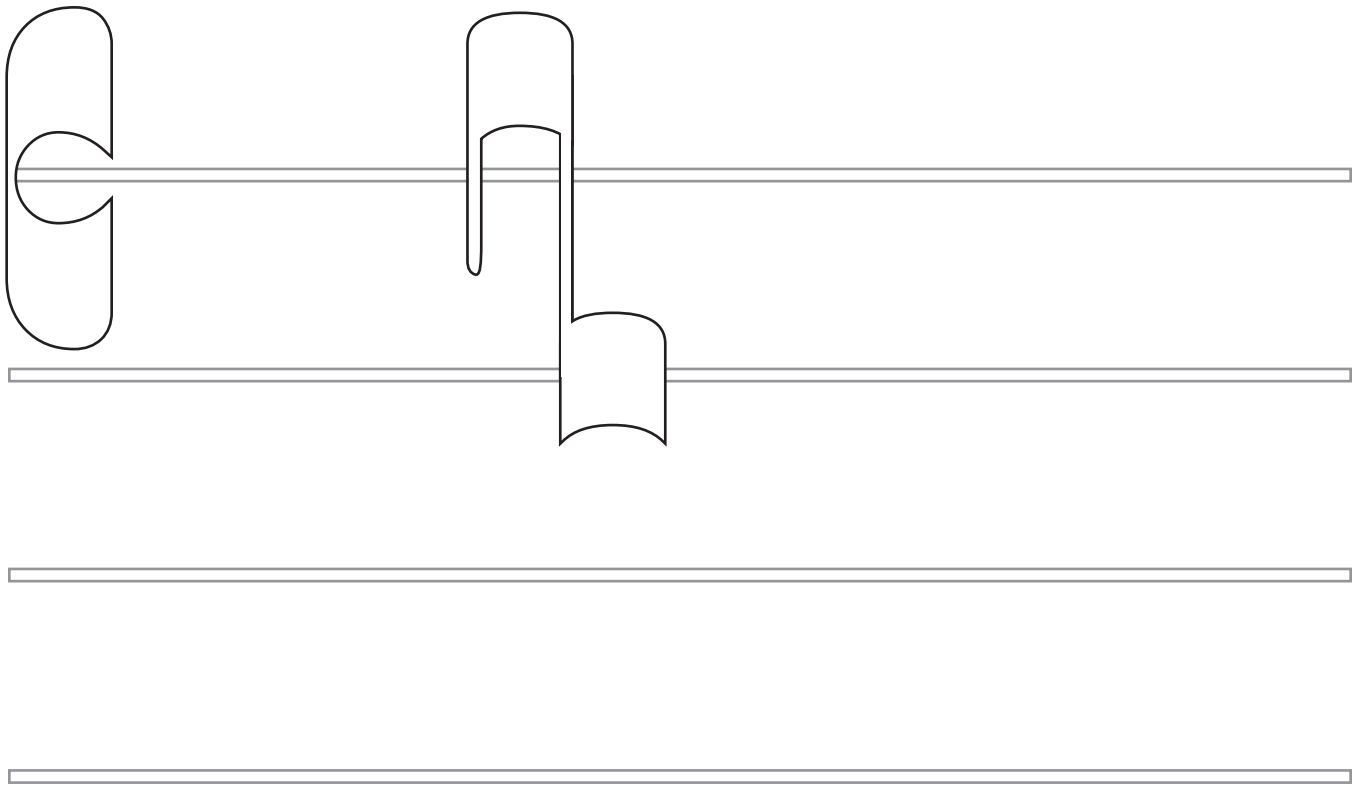

A Clivis at work.

Sing the top note then follow the line down to the second note.

Any neume group is always sung to just one vowel.



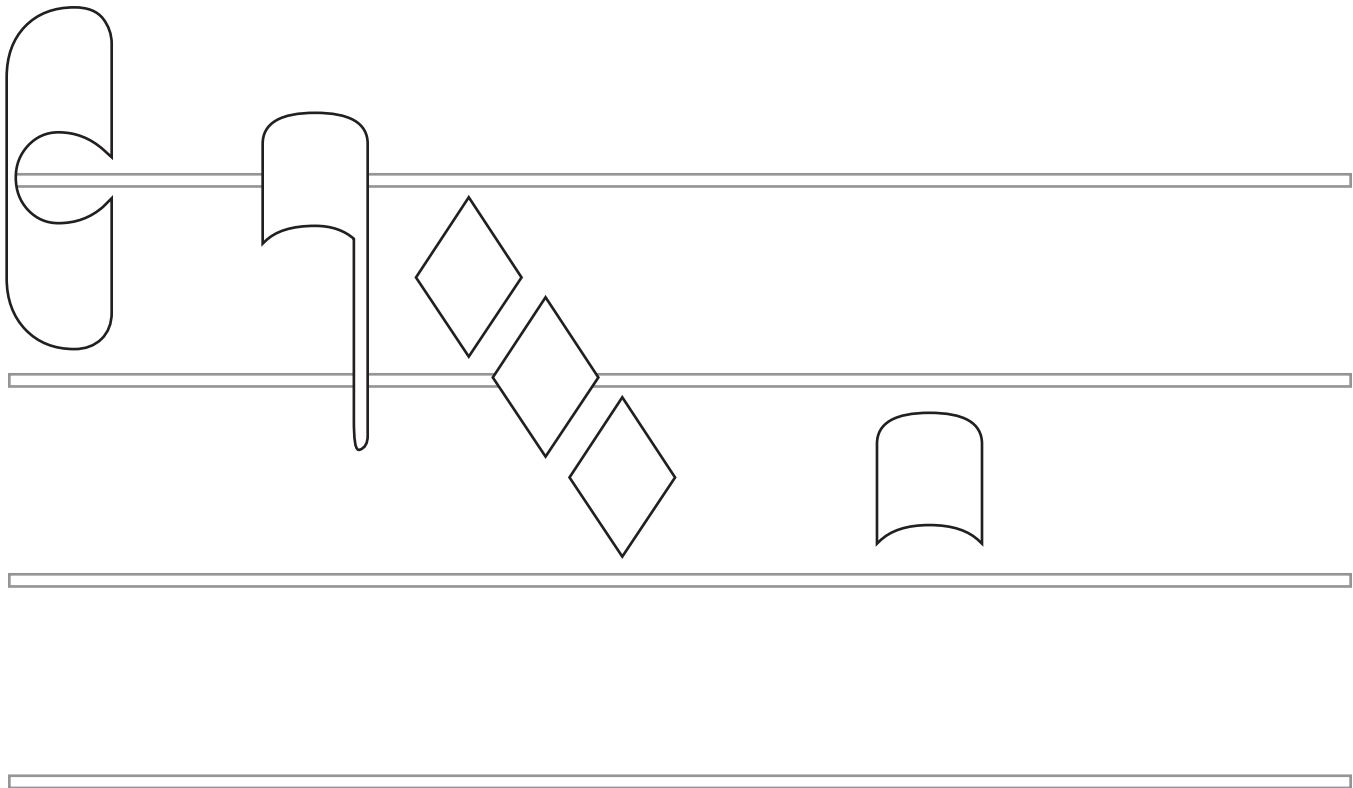

*A-*

*men.*

### Inclinatum

These diamond-shaped neumes are cool. They are part of a group. (see the line in on the Clivis?)

Here they tell you to stretch the "A" over four pitches. One vowel over four pitches  
And they show you the melody falling down the staff.

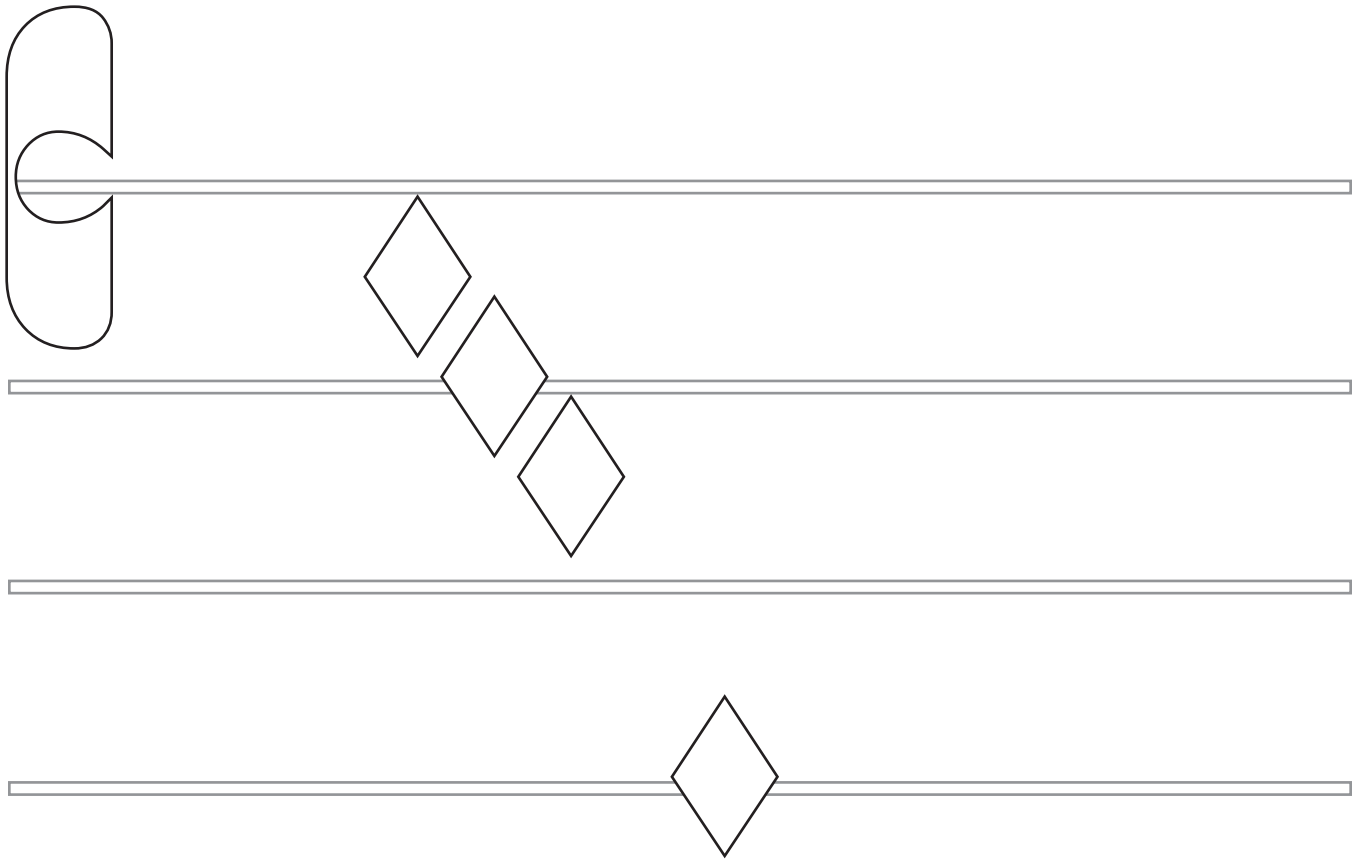

## Inclinatum

They can go from note to note in a scale or skip notes, leaping over ones that are not sung.

Inclinatum means *Leaning*. It is a punctum that is leaning. Even though there is a hop at the end of these four, they are all sung to the same vowel.

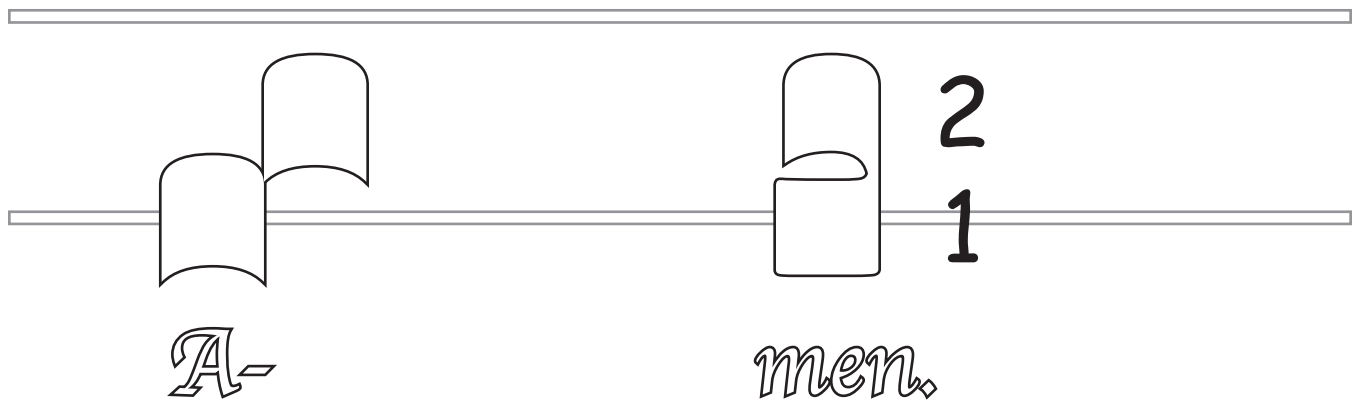
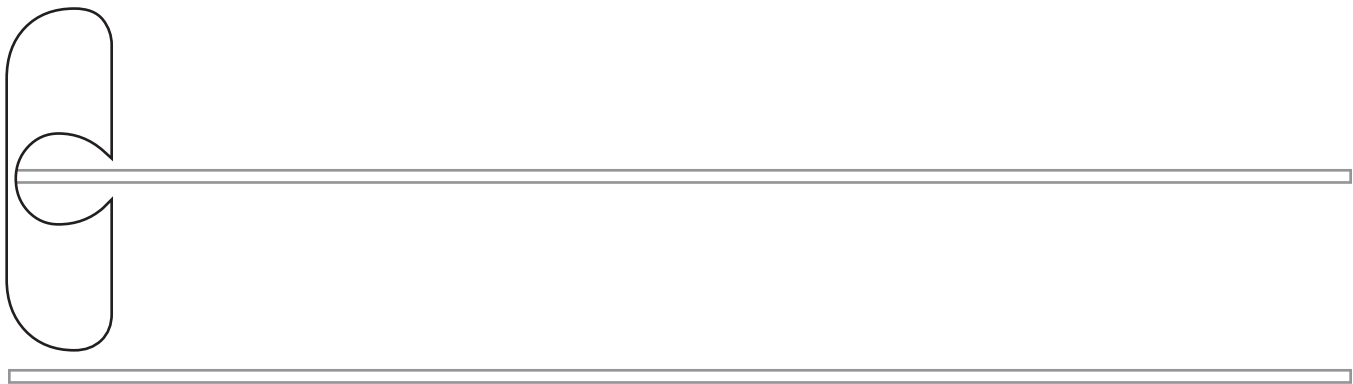

Podatus - Foot

When part of a word is sung to two notes, it can look like this. But the Podatus on the right above takes up less space and is sung just like the two notes above the A in Amen.

When two neumes are stacked, you always sing the lower one first. The stem can be stretched up to connect notes that are further apart.

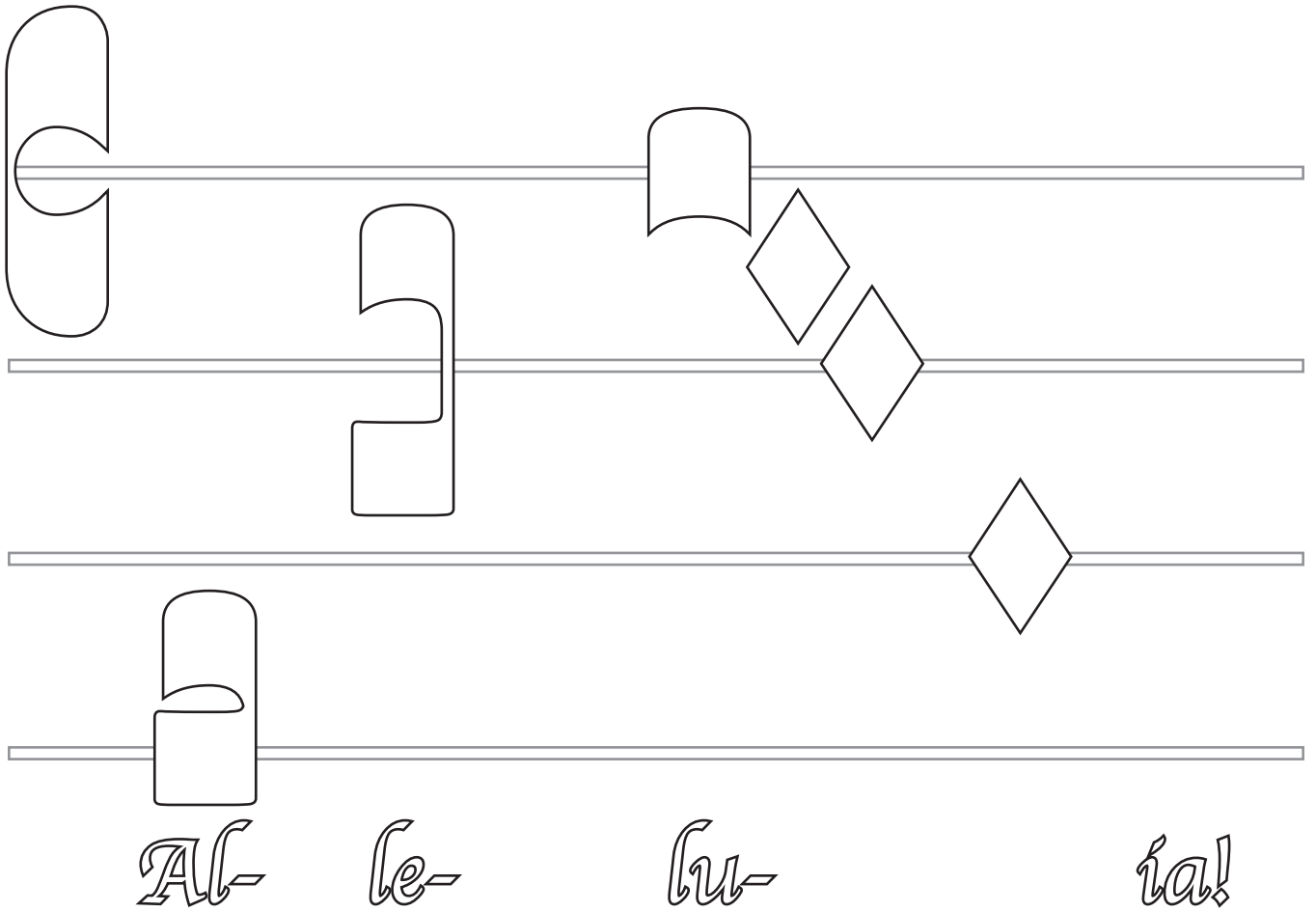

Podatus & Inclinatorum Neumes

Color these notes and the words. Color the word that you sing to it any colors you like.

There are three neume groups to sing above.

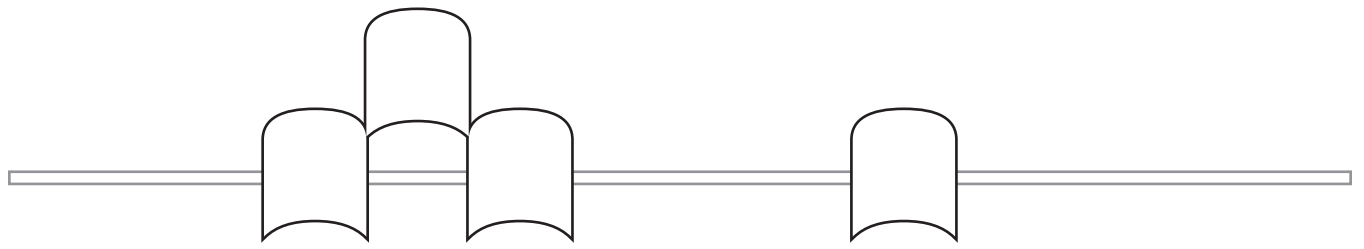

*A-*

*men.*

Torculus

Another building block of chant. Three notes.

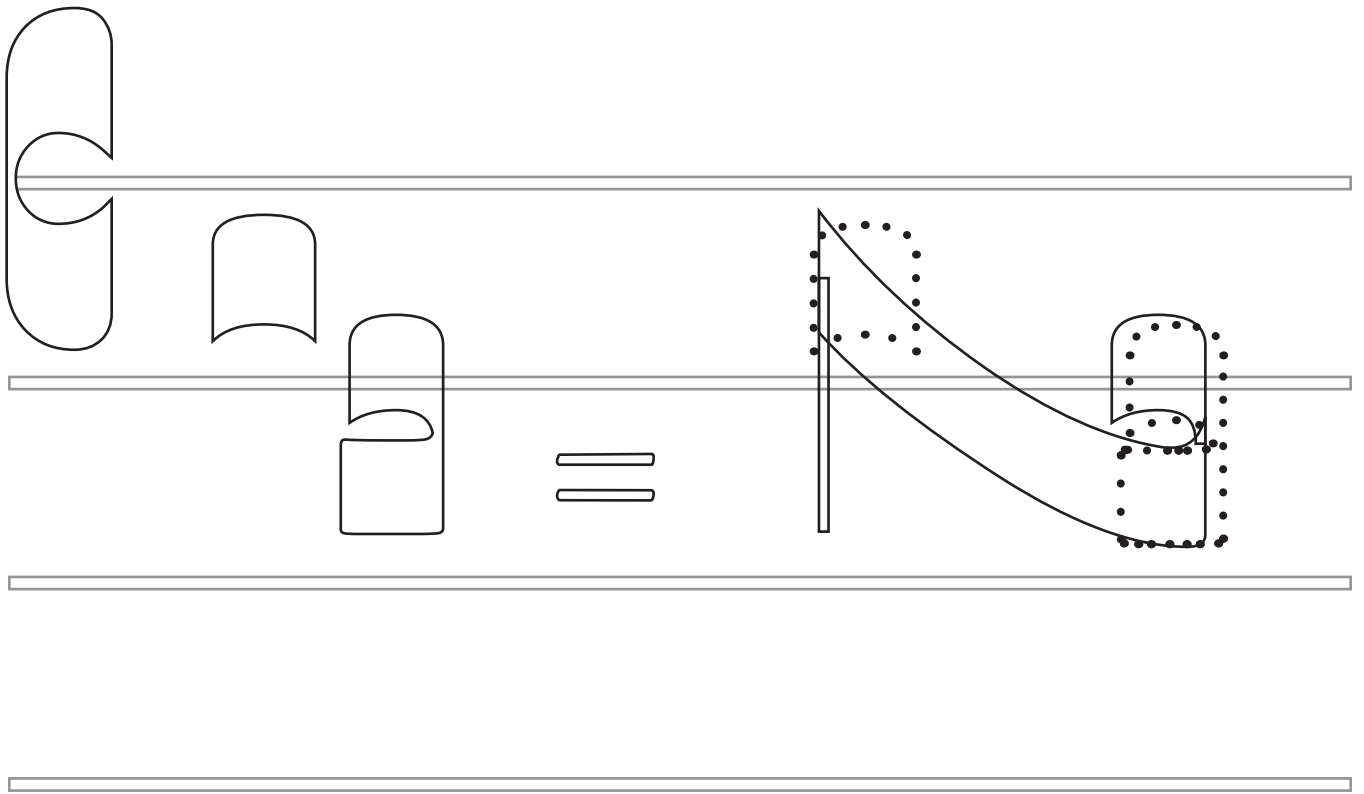

## Porrectus - Stretched

When you see a Porrectus, sing only the three notes that it outlines. The swoop is just decoration, an artist's way of moving from one line to another.

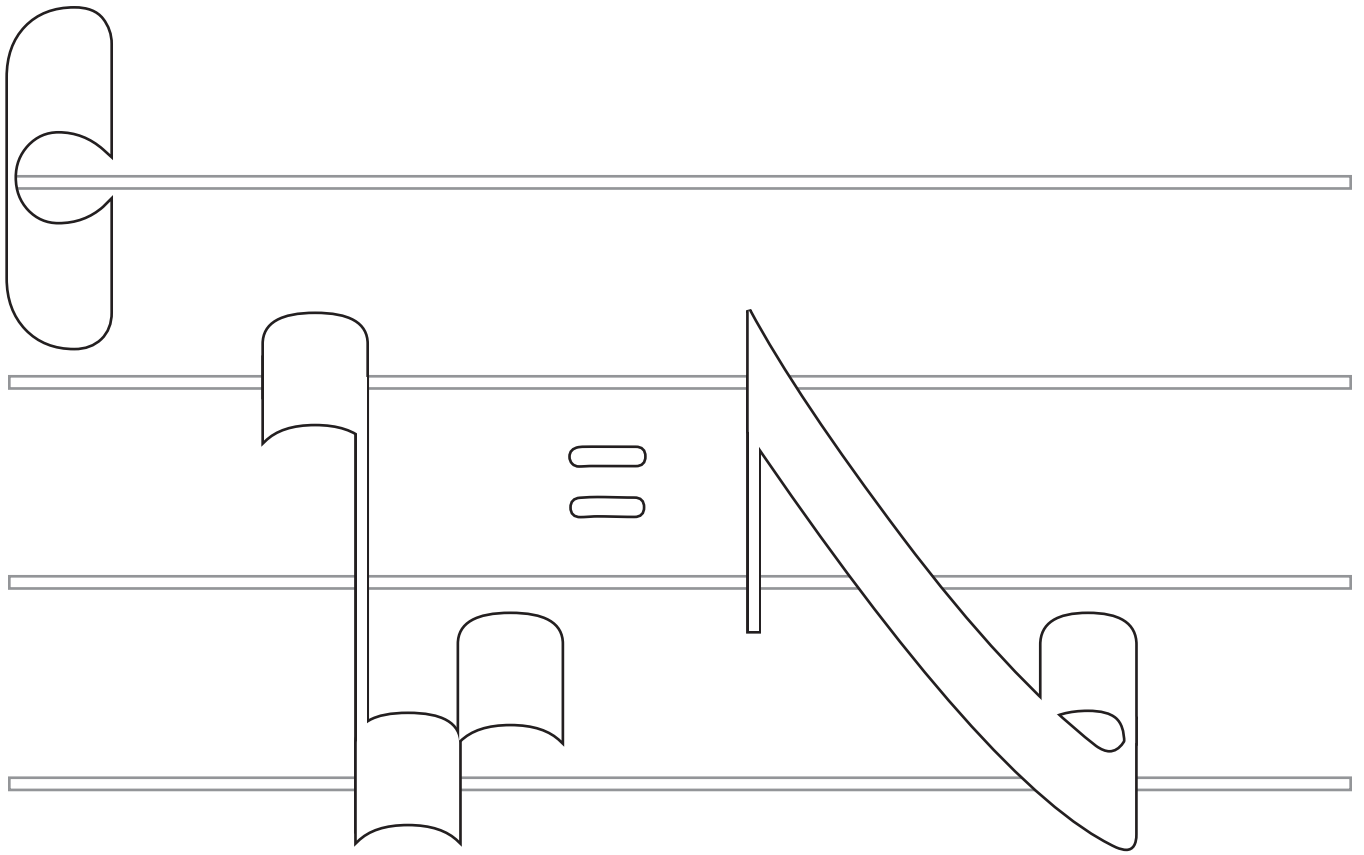

### Porrectus - Once again

On the left, three notes sung to the same syllable, on the right the way it is drawn as a Porrectus. Only the first pitch and last pitch of the "swoop" are sung.

fa

mi

re

do

ti

la

so

fa

mi

When Do moves, the colored staff lines move too.

Clef signs can move during a line or at the start of the next line.

Here Do moves down a line and above it now are Re on a space and and Mi on the top line  
 Where is Fa? Color Do and Fa their regular colors. Since the topline is not Do or Fa,  
 color it black.



ti

la

so

fa

mi

re

do

ti

la

Finally, it's Fa!

The Fa clef sticks a neume with a tail on the back of the Do clef.. It looks like a backpack with straps hanging down.

Here we have the Fa clef on the top line. Should we color the top line red now? If Do is on a line, we color the line green. Count down the staff. Is Do on a line?

ti

la

so

fa

mi

re

do

ti

la

Fa

Here we have the Fa clef on the second line. What line is red now?

If Do is on a line, we color the line green. Count up and down the staff using the Do Re Mi (solfege). Spaces are never colored. You still color Do and Fa neumes green & black.

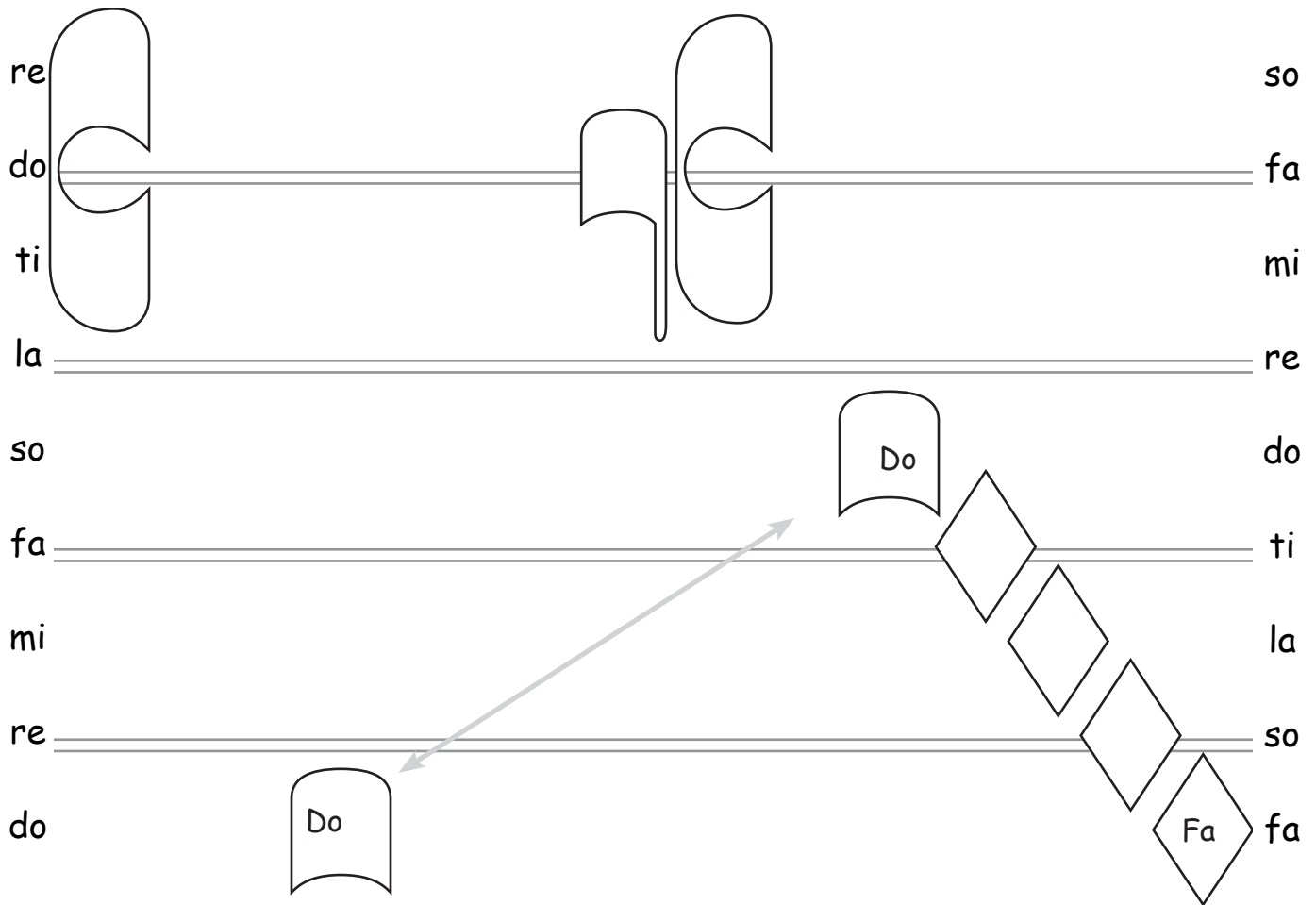

It's the same pitch.

Here we learn that a clef moves pitches that we sing. If you sing Do after the Do clef and a Fa Clef is inserted on the line, Do moves, but it is the same Do.

Why do this? Now the composer can write notes lower than Do - 4 of them, without having to add those little short ledger lines. These inclinatum, for example.

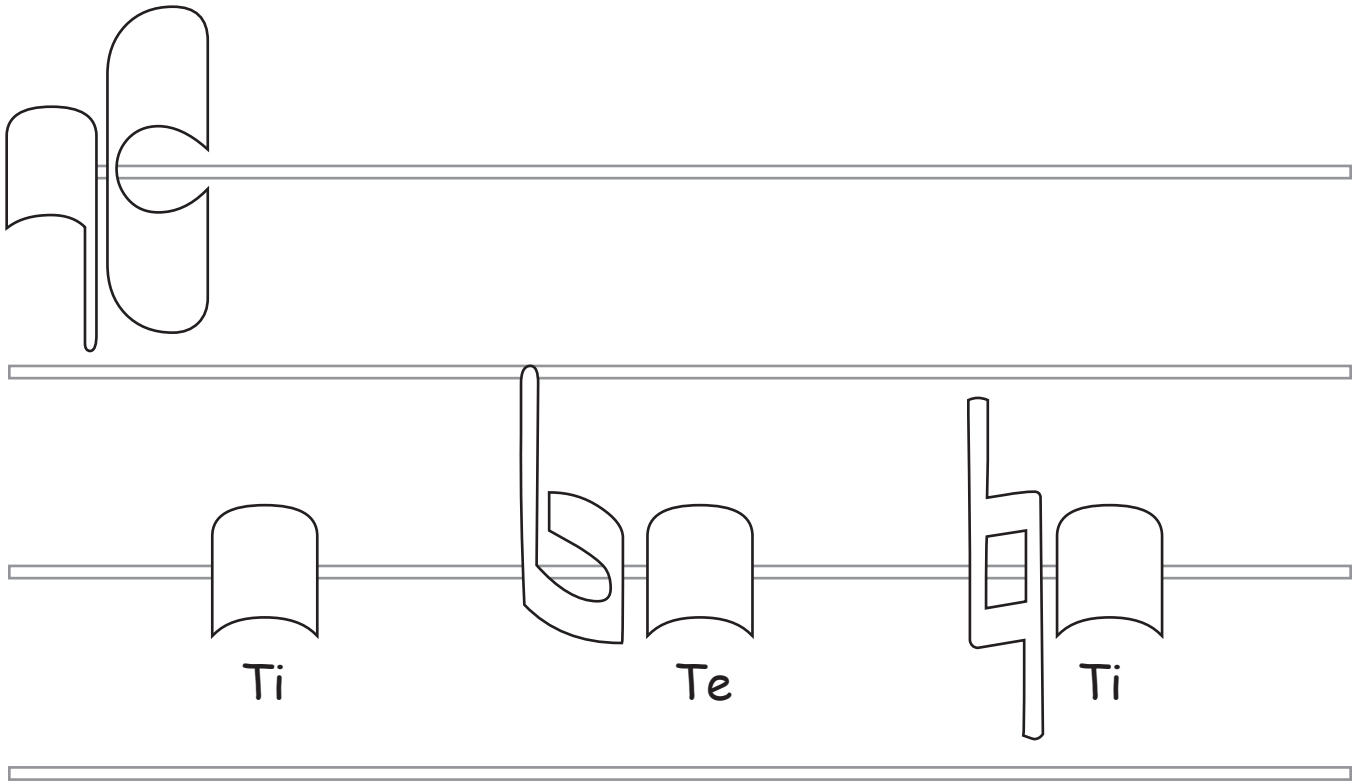

*Do -*

*mí -*

*ne*

Flat & Natural

Sometimes we sing the 8th pitch in chant: Te. It is Ti lowered halfway to LA. The "b" above tells you to sing Te, then the box-shaped natural "b" after it tells you to sing Ti again.

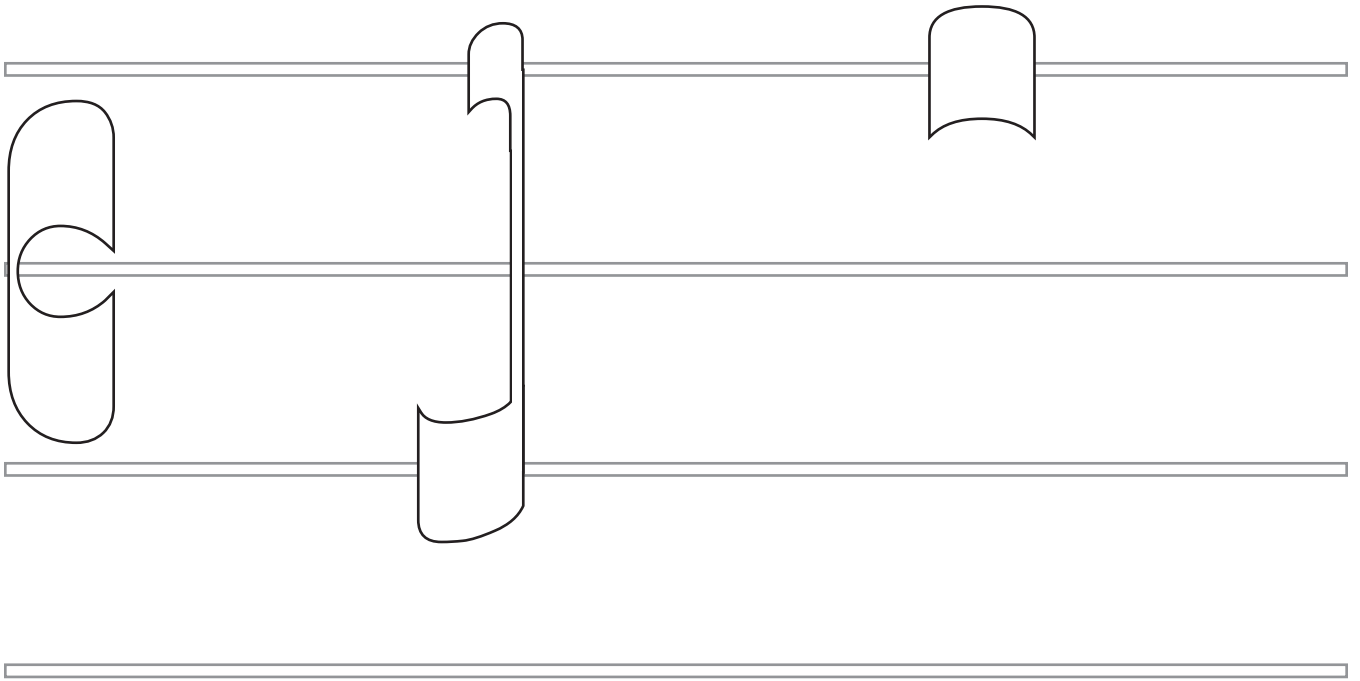

*Sanc-*

*tus*

Liquescent

Sing the large note first. The small note is then sung with a closed tone on syllables like "sa - nc". You end up making a smaller sound and "nc" so we use a smaller note to show it. Ask your director to show you how to do this. What line gets colored green here and which one red?

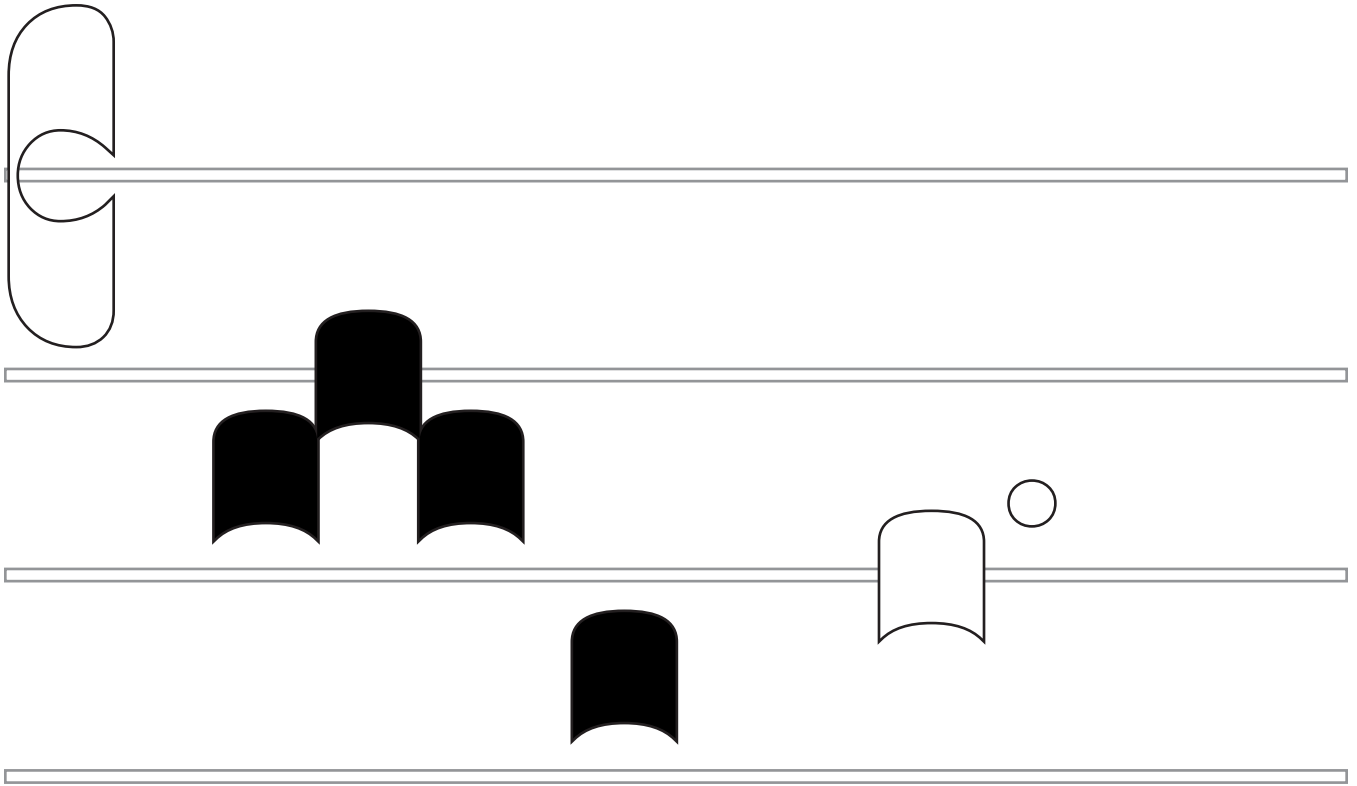

## HELD NOTES 1 • Punctum Mora - Dying Note

The dot after a neume doubles how long you sing it and usually tells you to let the sound soften and die away. *Punctum Mora* means dying note. The dot becomes part of the note, so it gets colored the same.

Watch the director to see if are supposed to get soft while singing this longer note.

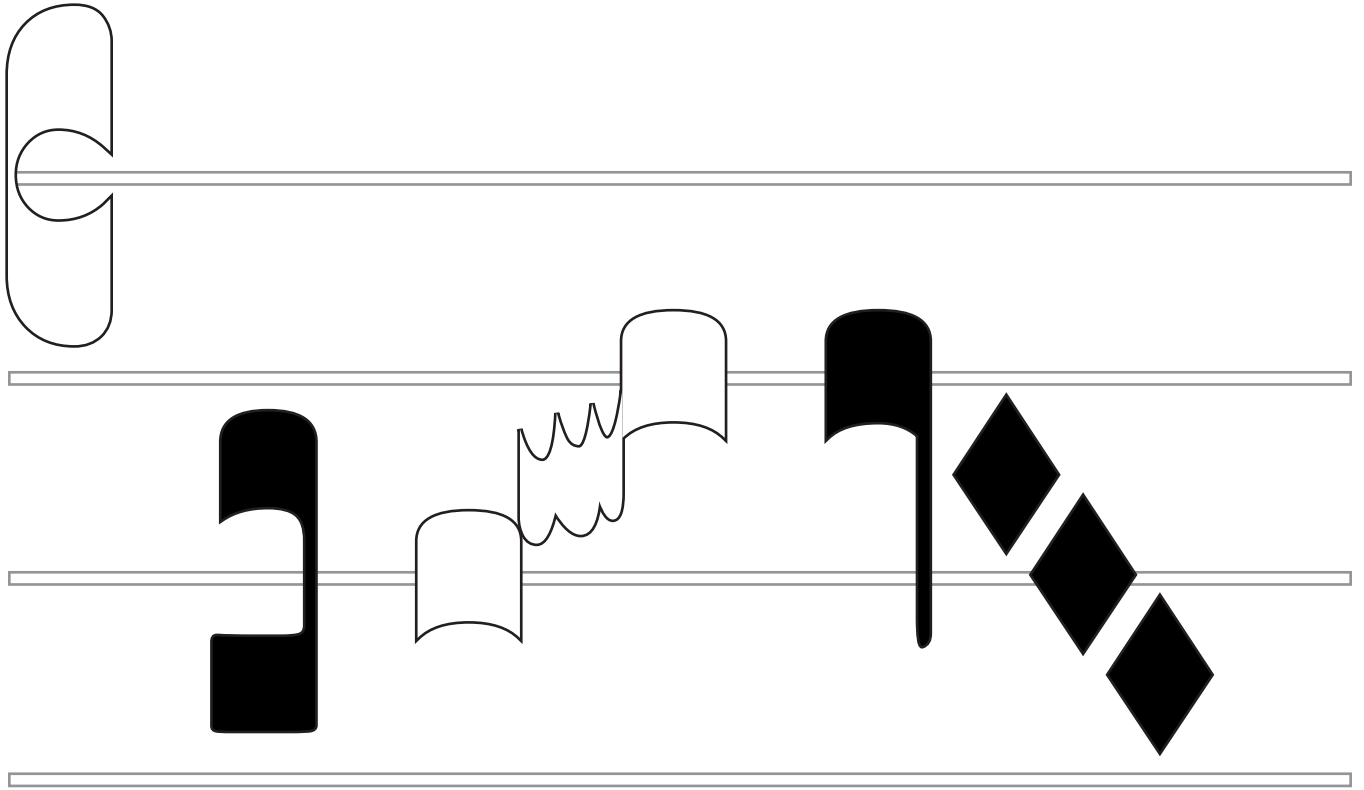

## HELD NOTE 2 • Quilisma - The Squiggly Note

The squiggly note tells you to lengthen the note before it. And then sing the squiggly note and all other notes one after the other.

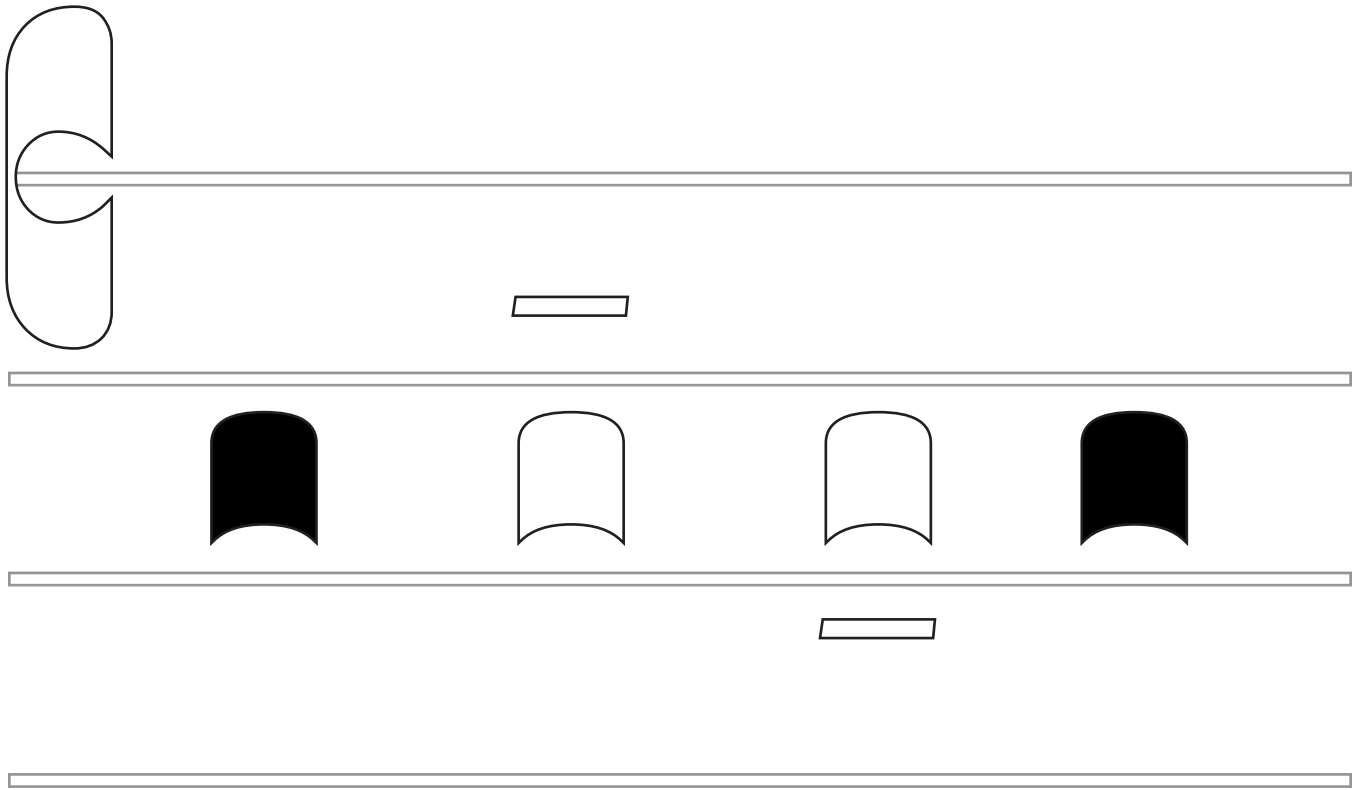

### HELD NOTE 3 • Horizontal Episema

The flat line above or below a note tells you to hold the note under it or over it as long as your director tells you to.



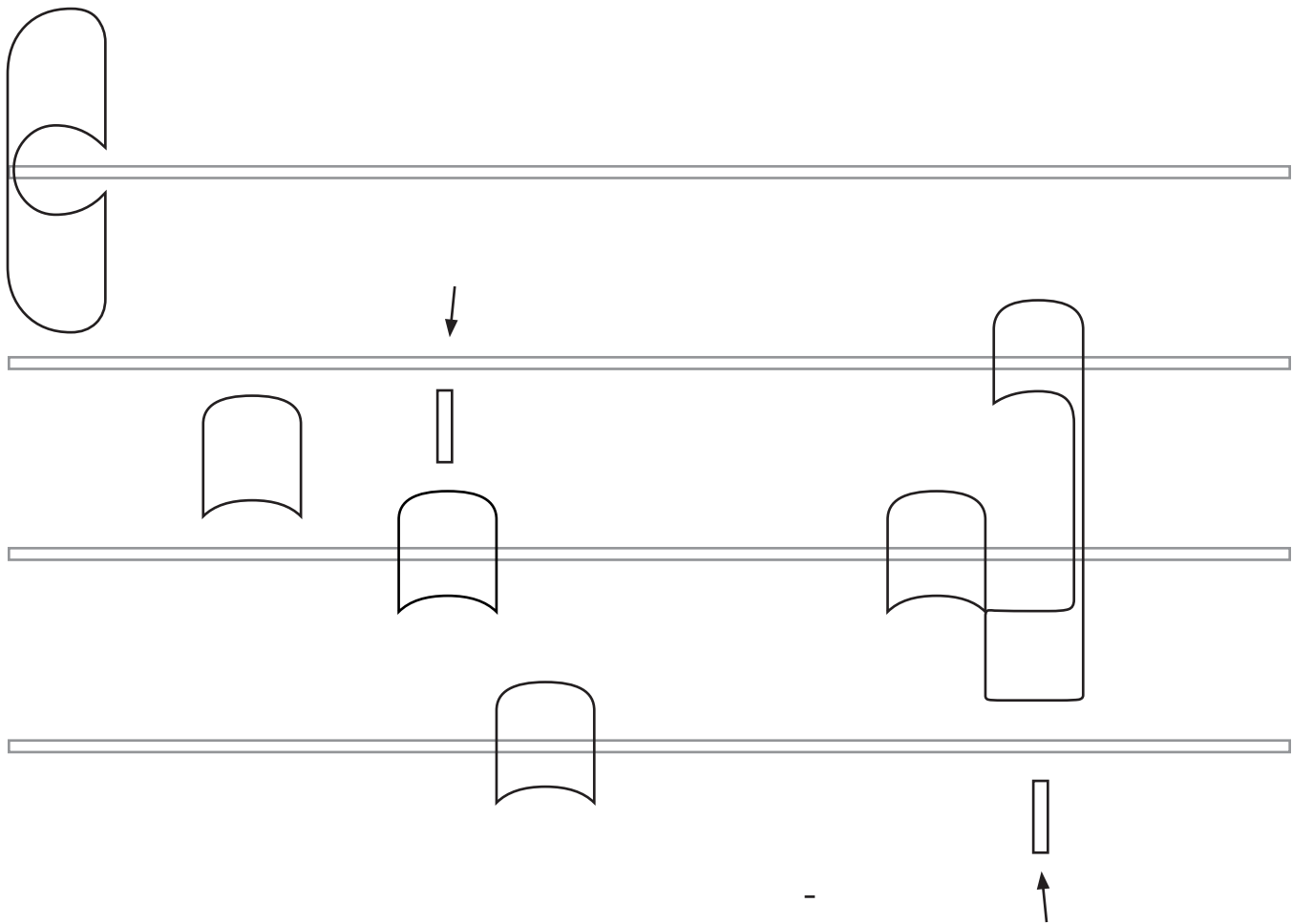

HELD NOTE 4 • Salicus but not the Vertical Episema

Salicus - hold!

A single note with a vertical line is not sung different from any other note when it is a vertical episema. Almost all the time this sign is just there to group notes for the director to consider. You hold it when it is a Salicus - a group of three notes together with a vertical episema sign under the second neume, the only note you hold.



*A-*

*men.*

### Stropha

When two or more notes are on the same line or space over one syllable of a word on the same line or space you sing the notes as if they were one note, with a little bump of sound on each one, without stopping the sound.

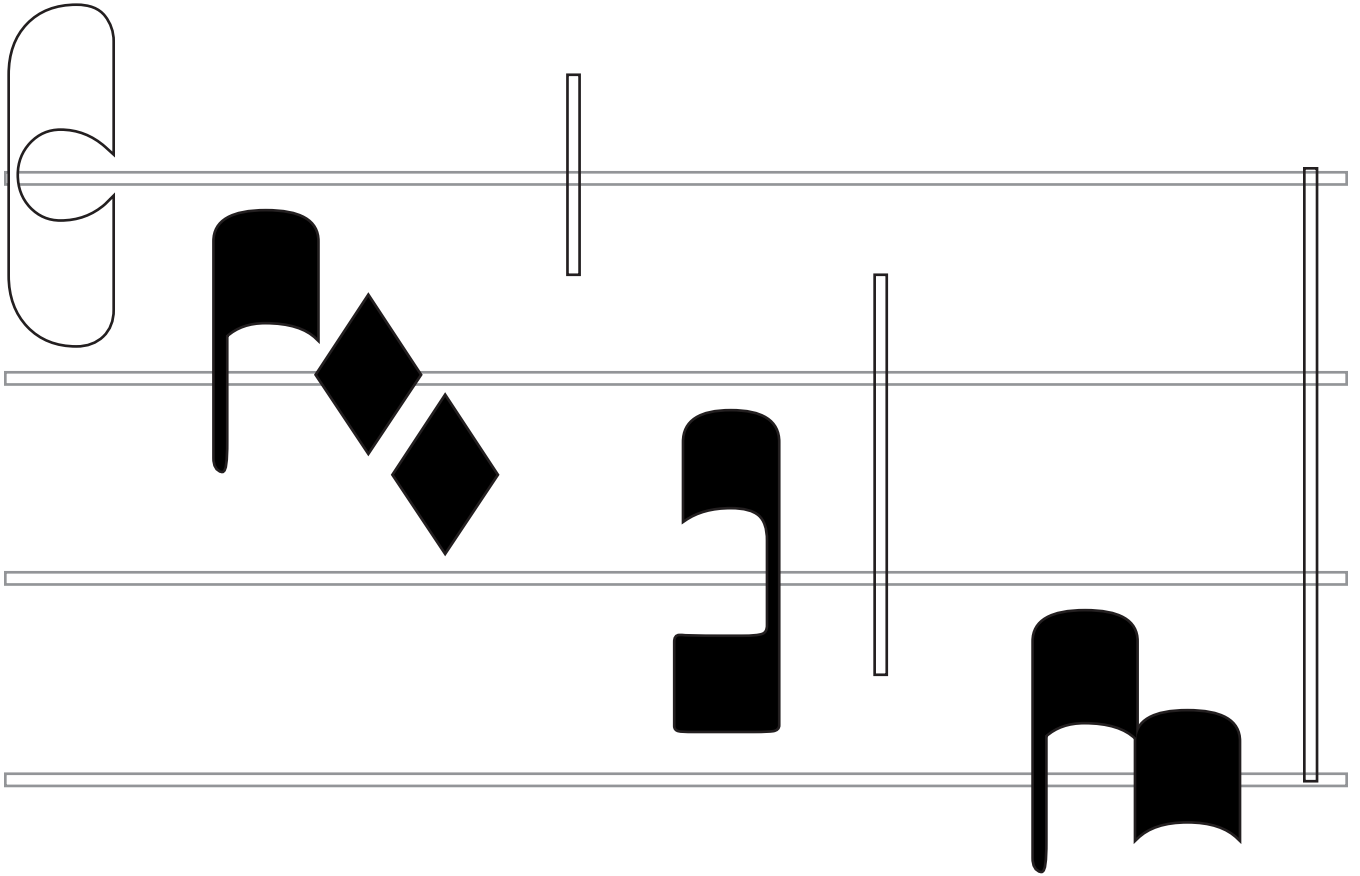

Bar lines - traffic signs.

The 1/4 line just helps you remember where you are.

The 1/2 bar means to stop and take a breath in some cases. Watch your director to see how long to break. The Full bar always means to stop and take a breath. Color all of these bar lines black.

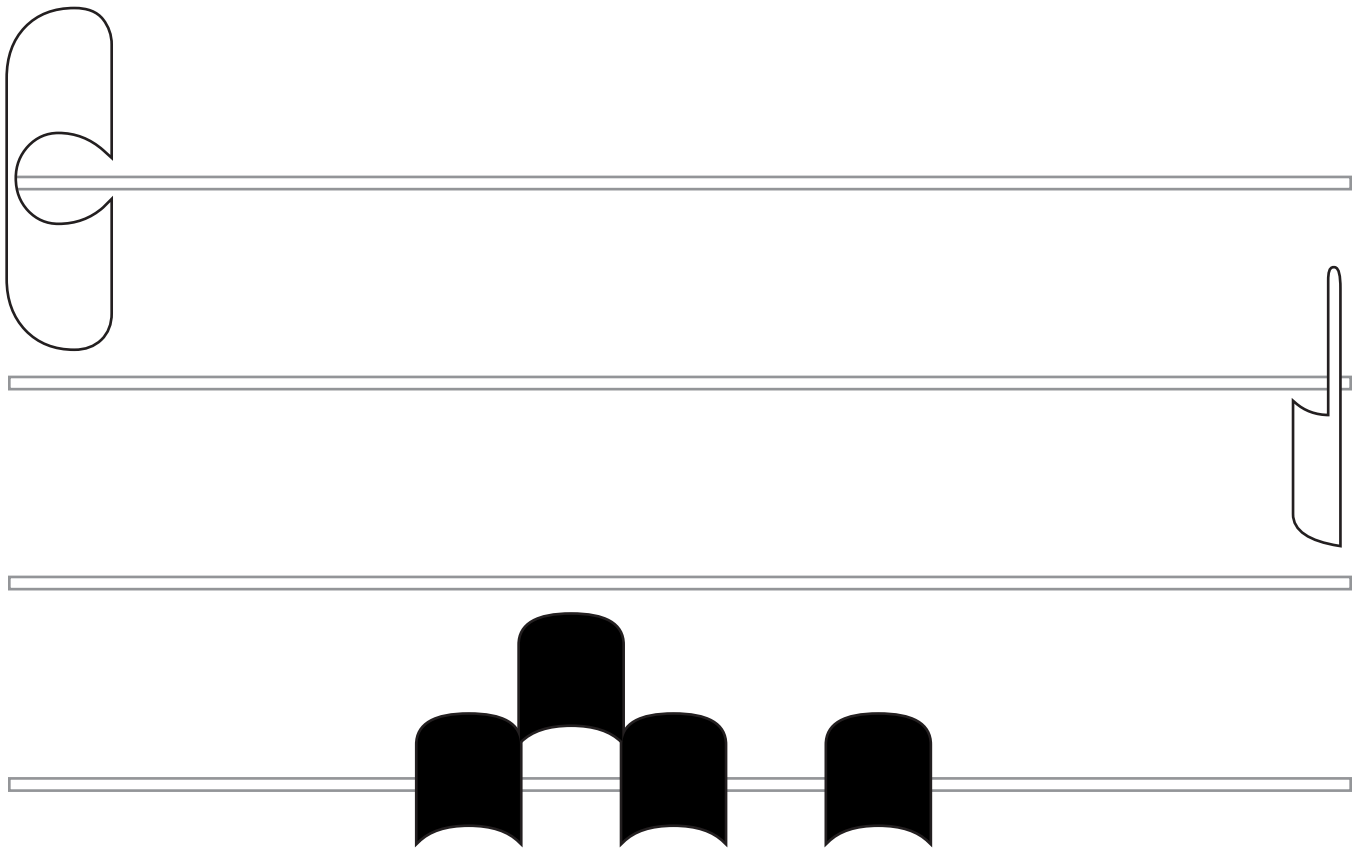

## Custos

These are always at the end of a line. You do not sing them, instead they tell you what the first note is on the next line.

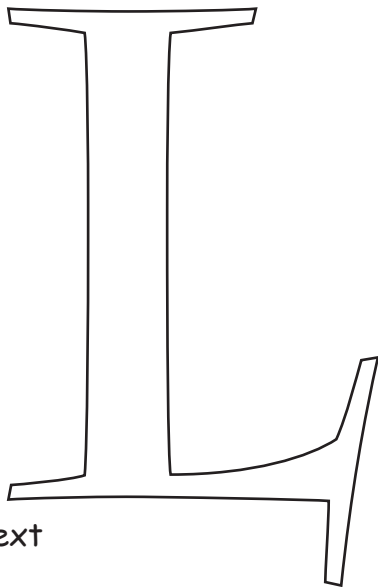
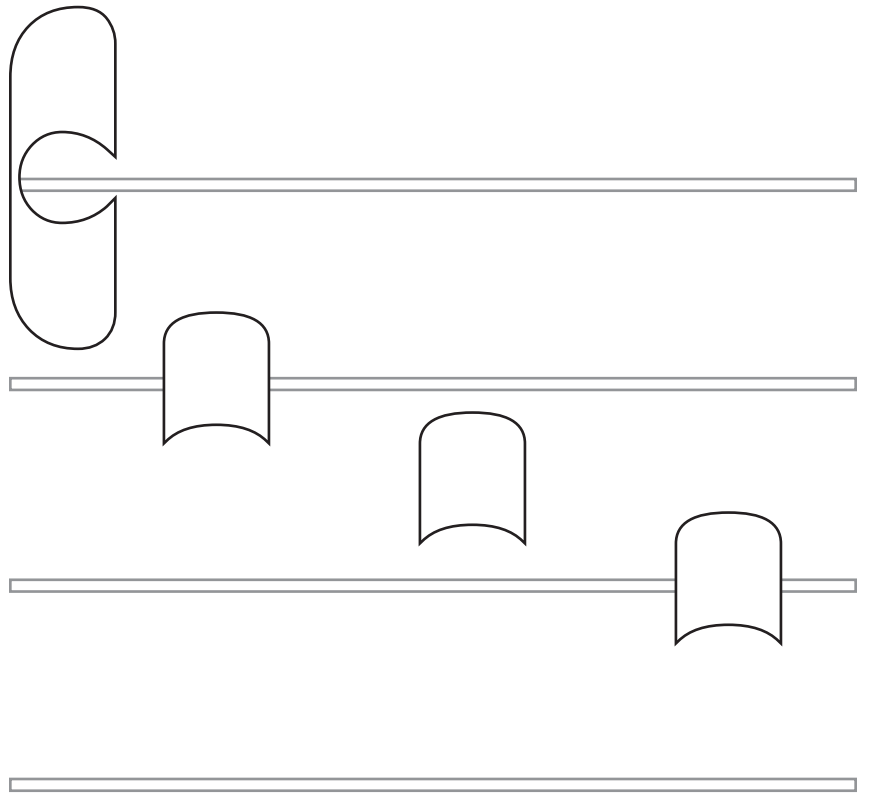

Text

AU-DA-MUS

Often the first letter of the first word is printed to the left of the first line of a chant. The next letter is capitalized under the first note, and the rest of the text follows. When "illuminated" by hand, these initials could be very colorful.

# Rules for singing chant - look at the next page:

1. Find the Clef. Is it Do or Fa?
2. Find the first note. Start from the clef and go down (or) to the first note
3. Find the last note using the list of pitches of lines and spaces.
4. Look for any of the four rhythm altering notes or signs:

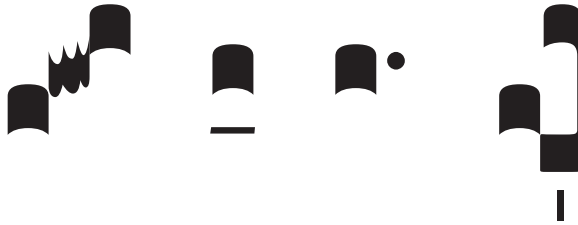

Now you are ready to begin studying the chant because you know:

- A. The Clef
- B. The First Note
- C. The Last Note
- D. Notes that may be held.

# 1. Do Clef

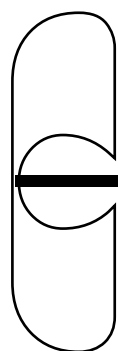

do

3. do

ti

ti

la

2.

la

4.

so

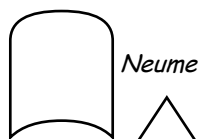

Neume

so



Neume



Punctum Mora

Neume

fa

Neume

mi

Neume

re

do





## Gregorian Chant Hymns

Learn to sing the melody to the sounds of Nu and Nah until you can sing each line without looking without a mistake.

Some of the words have more than one note to sing for a syllable. You have learned to recognize these neume groups that you sing this way. When you sing them stretch the "u" and "a" sound of Nu and Nah over them, starting with the N only on the first note.

Then when you sing the words of the hymn it will be easy for you to remember to do this with the words as well.

All the notes in chant are sung one after the other, as regular as a clock ticking except for the four HELD NOTES we learned. When those appear in the music, look up and watch your director. Your director will show you how long to hold them and then when to go on.

On the Punctum Mora, watch carefully to see how long to hold it but also in case your director decides to soften the note.

Almost all lines of chant music end softly, just as you speak a sentence and end it softly.

Gregorian Chant can be sung in any language. Why sing it in Latin then? Once you have mastered singing it in English, then singing it in Latin improves your singing voice and the sound of your choir. Latin, like Italian and Spanish, uses pure vowels and singers are taught these vowels to make the sound of their voice richer in any language, including English.

Odhead here in hiding, Thee we do adore.

Masked by these bare shadows, shape and nothing more,

See, Lord, at Thy service low lies here a heart,

Lost, all lost in wonder, at the God Thou art.

MUSIC: ADORO TE DEVOTE

- 1 Godhead here in hiding, whom I do adore,  
Masked by these bare shadows, shape and nothing more,  
See, Lord, at thy service low lies here a heart  
Lost, all lost in wonder at the God thou art.
- 2 Seeing, touching, tasting are in thee deceived:  
How says trusty hearing? that shall be believed;  
What God's Son has told me, take for truth I do;  
Truth himself speaks truly or there's nothing true.
- 3 On the cross thy godhead made no sign to men,  
Here thy very manhood steals from human ken:  
Both are my confession, both are my belief,  
And I pray the prayer of the dying thief.
- 4 I am not like Thomas, wounds I cannot see,  
But can plainly call thee Lord and God as he;  
Let me to a deeper faith daily nearer move,  
Daily make me harder hope and dearer love.
- 5 O thou our reminder of Christ crucified,  
Living Bread, the life of us for whom he died,  
Lend this life to me then: feed and feast my mind,  
There be thou the sweetness man was meant to find.
- 6 Bring the tender tale true of the Pelican;  
Bathe me, Jesu Lord, in what thy bosom ran---  
Blood whereof a single drop has power to win  
All the world forgiveness of its world of sin.
- 7 Jesu, whom I look at shrouded here below,  
I beseech thee send me what I thirst for so,  
Some-day to gaze on thee face to face in light  
And be blest for ever with thy glory's sight.  
Amen.

Translation of Gerard Manley Hopkins, S.J.

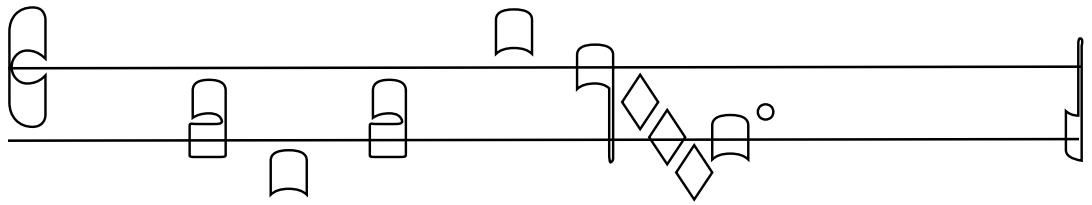

H

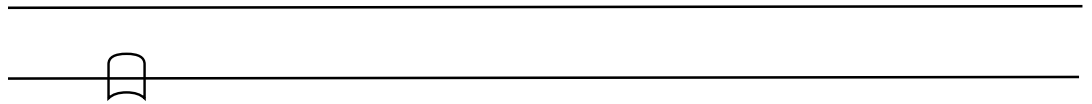

Ail, O star that pointest

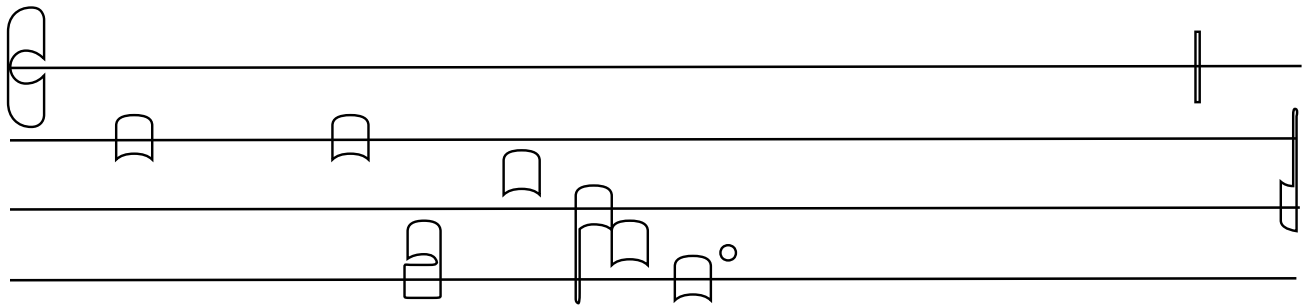

Towards the port of Heaven.

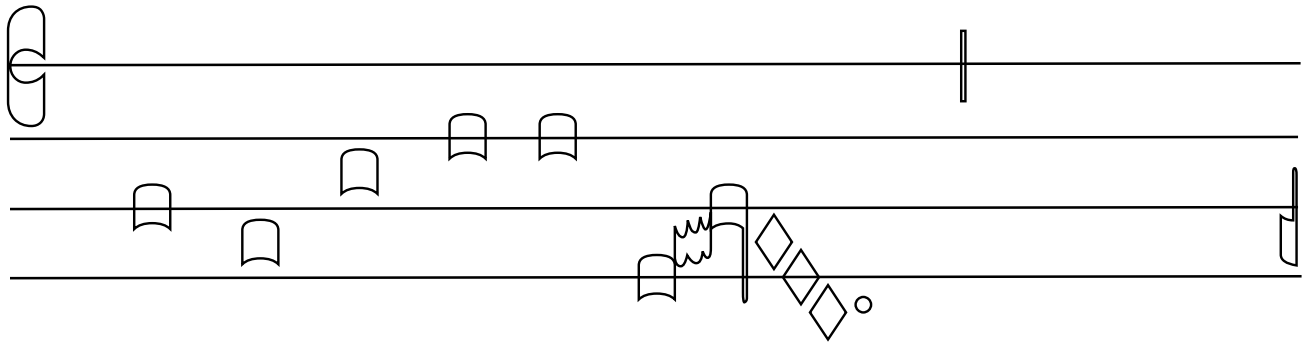

Thou to whom as maiden,

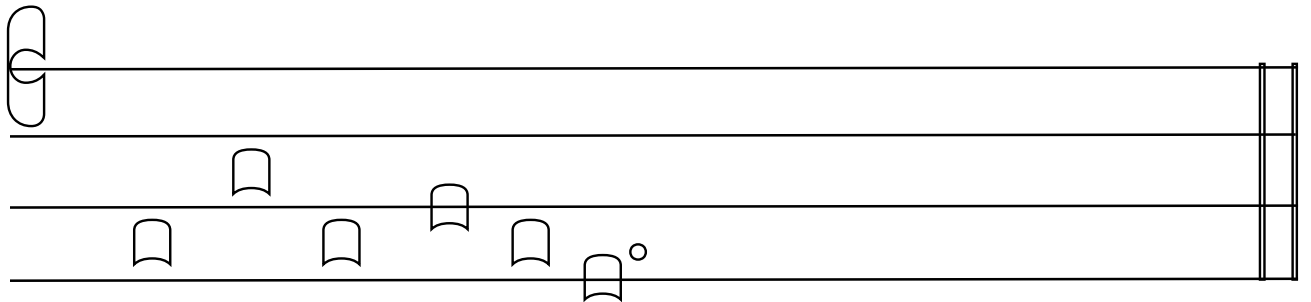

God for Son was gi- ven.

MUSIC: AVE MARIS STELLA

- 1 Hail, O star that pointest  
Towards the port of Heaven,  
Thou to whom as maiden  
God for Son was given.
- 2 When the salutation  
Gabriel had spoken,  
Peace was shed upon us,  
Eva's bonds were broken.
- 3 Bound by Satan's fetters,  
Health and vision needing,  
God will aid and light us  
At thy gentle pleading.
- 4 Jesu's tender mother,  
Make thy supplication  
Unto Him Who chose thee  
At His incarnation;
- 5 That, O matchless maiden,  
Passing meek and lowly,  
Thy dear Son may make us  
Blameless, chaste and holy.
- 6 So, as now we journey  
Aid our weak endeavor,  
Till we gaze on Jesus,  
And rejoice forever.
- 7 Father, Son and Spirit,  
Three in One confessing,  
Give we equal glory,  
Equal praise and blessing.

Re-a- tor of the stars of night,

Thy people's ev- er- lasting light,

Je--su, Redeemer, save us all,

and hear Thy servants when they call.

MUSIC: CREATOR ALME SIDERUM

- 1 Creator of the stars of night,  
Thy people's everlasting light,  
Jesu, Redeemer, save us all,  
And hear Thy servants when they call.
- 2 Thou, grieving that the ancient curse  
Should doom to death a universe,  
Hast found the medicine, full of grace,  
To save and heal a ruined race.
- 3 Thou cam'st, the Bridegroom of the bride,  
As drew the world to evening-tide;  
Proceeding from a virgin shrine,  
The spotless Victim all divine.
- 4 At Whose dread Name, majestic now,  
All knees must bend, all hearts must bow;  
And things celestial Thee shall own,  
And things terrestrial, Lord alone.
- 5 O Thou Whose coming is with dread  
To judge and doom the quick and dead,  
Preserve us, while we dwell below,  
From every insult of the foe.
- 6 To God the Father, God the Son,  
And God the Spirit, Three in One,  
Laud, honor, might, and glory be  
From age to age eternally.

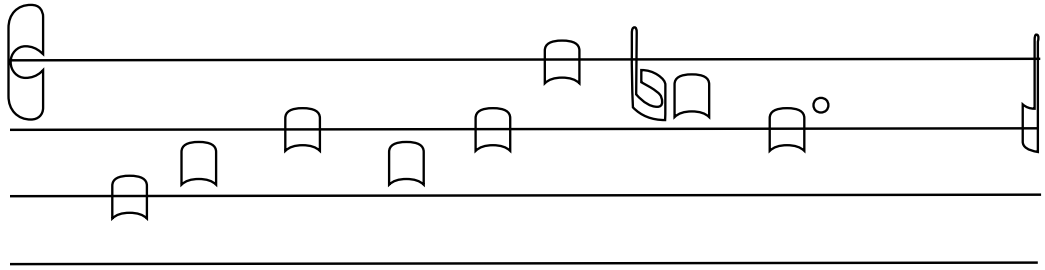
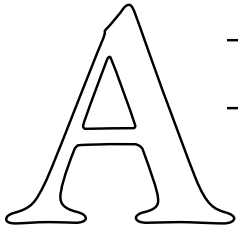

T the cross her station keeping

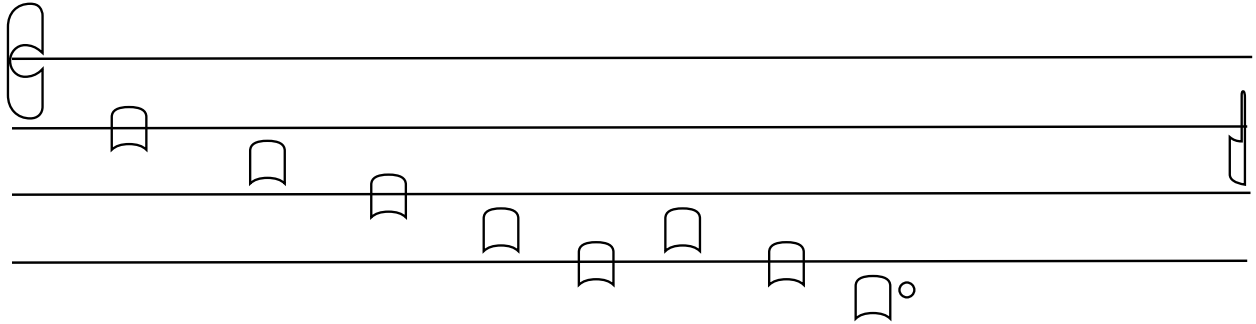

Stood the mournful mo-ther weeping,

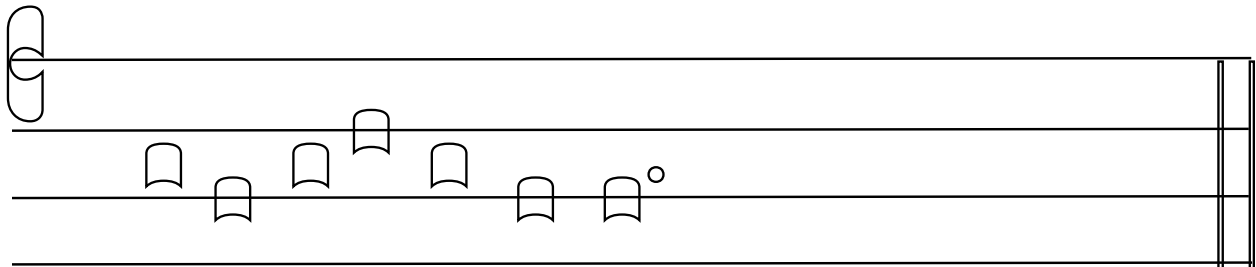

Close to Je-sus at the last.

MUSIC: STABAT MATER



1 At the cross her station keeping,  
stood the mournful mother weeping,  
close to Jesus at the last.

2 Through her soul, of joy bereavèd,  
bowed with anguish, deeply grievèd,  
now at length the sword hath passed.

3 O, that blessed one, grief-laden,  
blessed Mother, blessed Maiden,  
Mother of the all-holy One;

4 O that silent, ceaseless mourning,  
O those dim eyes, never turning  
from that wondrous, suffering Son.

5 Who, on Christ's dear mother gazing,  
in her trouble so amazing,  
born of woman, would not weep?

6 Who, on Christ's dear Mother thinking,  
such a cup of sorrow drinking,  
would not share her sorrows deep?

7 For His people's sins, in anguish,  
there she saw the victim languish,  
bleed in torments, bleed and die.

8 Saw the Lord's anointed taken,  
saw her Child in death forrsaken,  
heard His last expiring cry.

9 In the passion of my Maker,  
be my sinful soul partaker,  
may I bear with her my part;

10 Of His passion bear the token,  
in a spirit bowed and broken  
bear His death within my heart.

11 May His wounds both wound and  
heal me,  
he enkindle, cleanse, and heal me,  
be His cross my hope and stay.

12 May he, when the mountains quiver,  
from that flame which burns for ever  
shield me on the judgment day.

13 Jesus, may thy cross defend me,  
and thy saving death befriend me,  
cherished by thy deathless grace:

14 When to dust my dust returneth,  
grant a soul that to Thee yearneth  
in thy paradise a place.

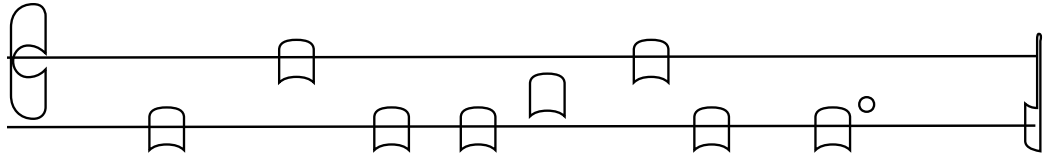

B

Right tor-ches in the darkest night

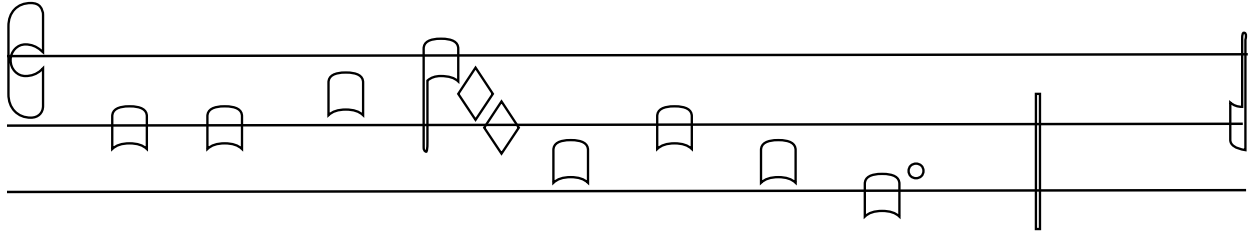

The saints of God in light yet shine,

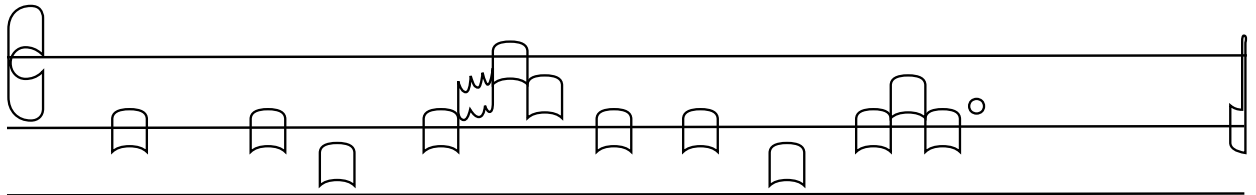

Lord, let our wit- ness rise with theirs

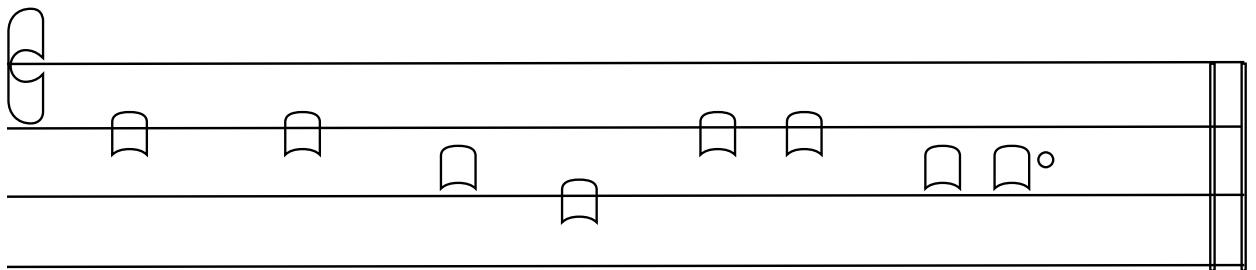

And through their pray'rs give grace divine.

TEXT: VINCENT UHER

- 1     Bright torches in the darkest night,  
          The saints of God as lights yet shine.  
Lord, let our witness rise with theirs,  
          And through their prayers give grace divine.
  
- 2     A dimly burning wick were we,  
          But now our faith fills with thy fire  
For thou art all consuming love —  
          Thy perfect will our hearts desire.
  
- 3     Unite thy saints through every age  
          And cleansed from sin lift us above,  
O Father, Son, and Holy Ghost,  
          One God in glory, one in love. Amen.

Text: Vincent Uher

Text by Vincent Uher is licensed under a Creative Commons Attribution 3.0 License, This permits copying and sharing except for commercial purposes. Text was originally ©2006.

E- sus, Thou Joy of Lov-ing hearts,

Thou Fount of life, Thou Light of men,

From the best bliss that earth imparts

We turn un-filled to Thee a-gain.

MUSIC: JESU DULCIS MEMORIA

- 1 Jesus, Thou Joy of loving hearts,  
Thou Fount of life, Thou Light of men,  
From the best bliss that earth imparts  
We turn unfilled to Thee again.
- 2 Thy truth unchanged hath ever stood;  
Thou savest those that on Thee call;  
To them that seek Thee Thou art good,  
To them that find Thee all in all.
- 3 We taste Thee, O Thou living Bread,  
And long to feast upon Thee still;  
We drink of Thee, the Fountain-head,  
And thirst our souls from Thee to fill.
- 4 Our restless spirits yearn for Thee,  
Where'er our changeful lot is cast;  
Glad when Thy gracious smile we see,  
Blest when our faith can hold Thee fast.
- 5 O Jesus, ever with us stay,  
Make all our moments calm and bright;  
Chase the dark night of sin away,  
Shed o'er the world Thy holy light.

Bernard of Clairvaux, Translator: Ray Palmer

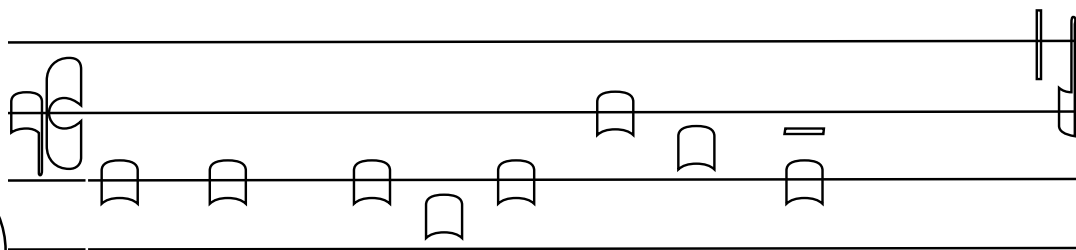
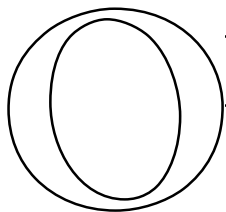

Come, Redeemer of the earth,

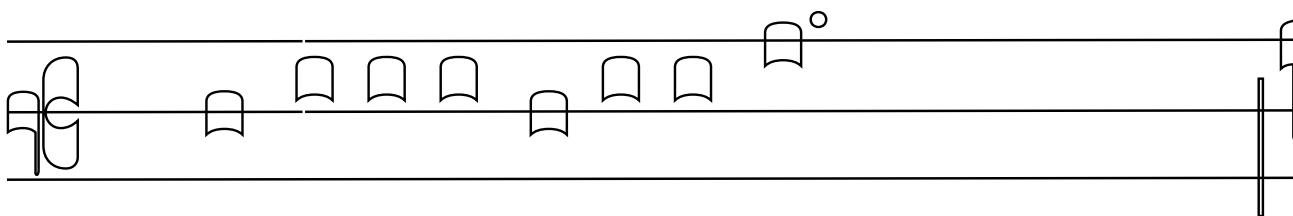

and manifest Thy virgin-birth

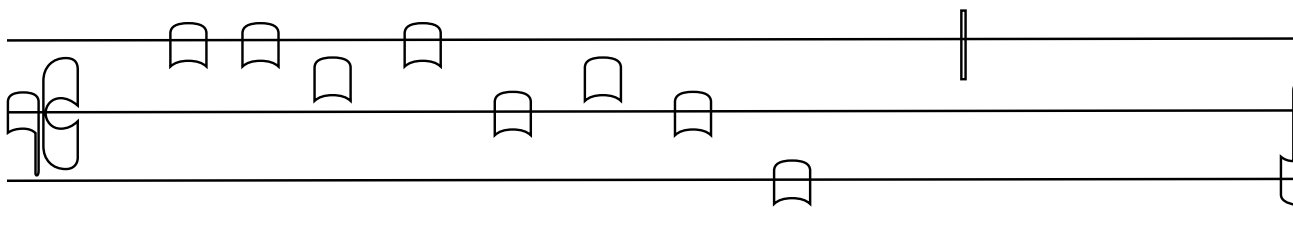

Let every age in wonder fall:

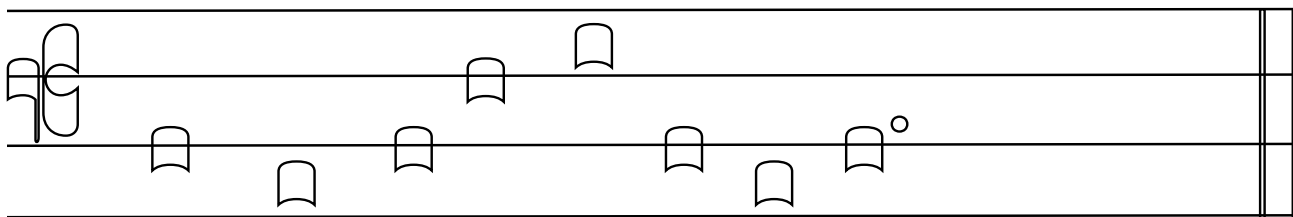

such birth be-fits the God of all.

MUSIC: VENI, REDEMPTOR GENTIUM

- 1 O come, Redeemer of the earth,  
and manifest thy virgin-birth.  
Let every age in wonder fall:  
such birth befits the God of all.
- 2 Begotten of no human will  
but of the Spirit, Thou art still  
the Word of God in flesh arrayed,  
the promised fruit to man displayed.
- 3 The Virgin's womb that burden gained,  
its virgin honor still unstained.  
The banners there of virtue glow;  
God in his temple dwells below.
- 4 Proceeding from His chamber free  
that royal home of purity  
a giant in twofold substance one,  
rejoicing now His course to run.
- 5 O equal to the Father, Thou!  
gird on Thy fleshly mantle now;  
the weakness of our mortal state  
with deathless might invigorate.
- 6 Thy cradle here shall glitter bright,  
and darkness breathe a newer light  
where endless faith shall shine serene  
and twilight never intervene.
- 7 All praise, eternal Son, to Thee,  
whose advent sets Thy people free,  
whom, with the Father, we adore,  
and Holy Ghost, for evermore. Amen.

# Index

At The Cross.....	64
Bar Lines .....	51
Bright Torches .....	66
Clefs.....	15-7
Clivis.....	31-32
Connections .....	30
Creator of the Stars Of Night.....	62
Custos .....	52
Do Clef.....	13
Fa Clef .....	41-43
Flat .....	44
Godhead Here I Hiding .....	58
Hail, O Star That Pointest .....	60
Held Notes .....	46-47
Horizontal Episema.....	48
Illuminated Text.....	53
Inclinatum.....	33-34, 36
Jesus Thou Joy .....	68
Ledger Lines.....	8
Liquescent.....	45
Natural .....	44
Neumes.....	9
O Come, Redeemer .....	70
Podatus .....	35, 36
Porrectus .....	38-39
Punctum .....	10-12
Punctum Mora .....	46
Quilisma .....	47
Salicus .....	49
Scale .....	21-8
Staff.....	6-7
Staff Lines.....	18-20
Stropha .....	50
Torculus .....	37
Vertical Episema .....	49
Virga.....	31



